

FRU (Field Replaceable Unit) list

This chapter gives you the FRU (Field Replaceable Unit) listing in global configurations of AL1511. Refer to this chapter whenever ordering for parts to repair or for RMA (Return Merchandise Authorization).

NOTE : Please note WHEN ORDERING FRU PARTS, that you should check the most up-to-date information available on your regional web or channel(<http://aicsl.acer.com.tw/spl/>). For whatever reasons a part number change is made, it will not be noted in the printed Service Guide. For ACER-AUTHORIZED SERVICE PROVIDERS, your Acer office may have a DIFFERENT part number code to those given in the FRU list of this printed Service Guide. You MUST use the local FRU list provided by your regional Acer office to order FRU parts repair and service of customer machines.

NOTE: To scrap or to return the defective parts, you should follow the local government ordinance or regulations on how best to dispose it, or follow the rules set by your regional Acer office on how to return it.

SCHEMATIC DIAGRAM

L5T MSTAR MB RSDS/LVDS

CONTENTS

SCHEMATIC	SHEET
CONTENT	1
BLOCK DIAGRAM	2
VGA AND TMDS INPUT	3
SCALAR MST8116A	4
MCU AND BOTTON CONTROL	5
Panel interface	6
Audio	7

		PROJECT : L5T Quanta Computer Inc.	
CONTENT			
Size	Document Number	CONTENT	Rev B
Date:	Friday, February 27, 2004	Sheet	1 of 7

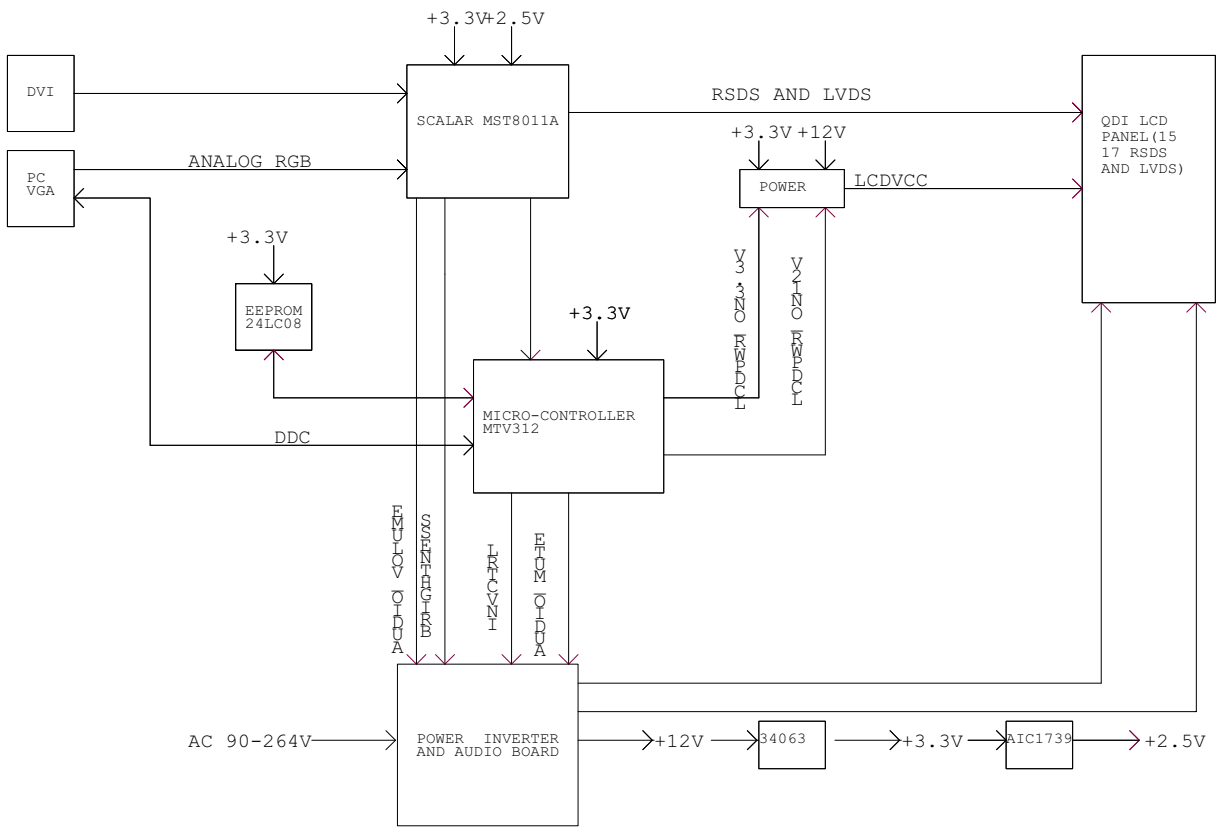

 PROJECT : L5T Quanta Computer Inc.		Title	
		BLOCK DIAGRAM	
Size	Document Number	BLOCK DIAGRAM	
Date	Friday, February 27, 2004	Sheet	2 of 7

PAGE 1. VGA INPUT

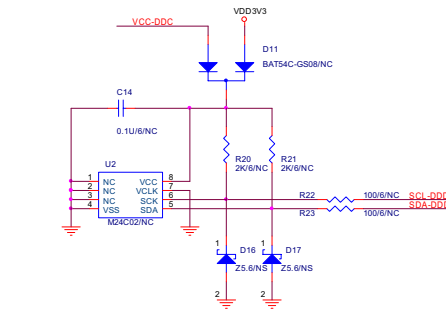
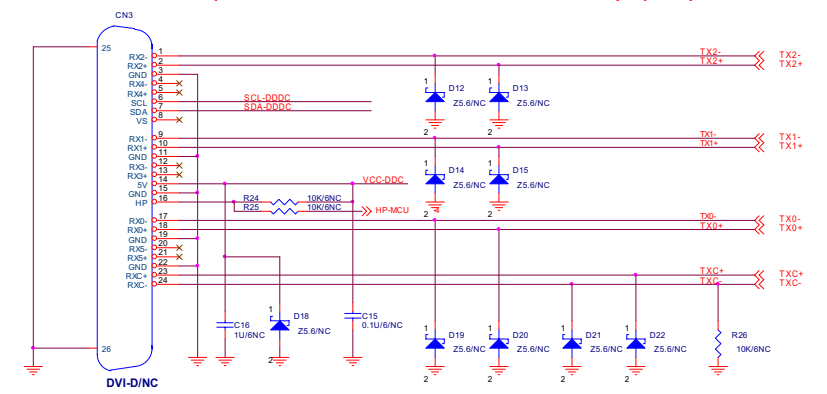
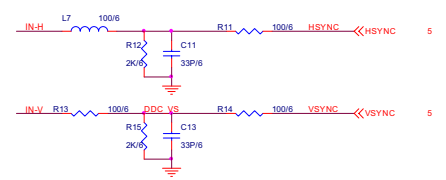
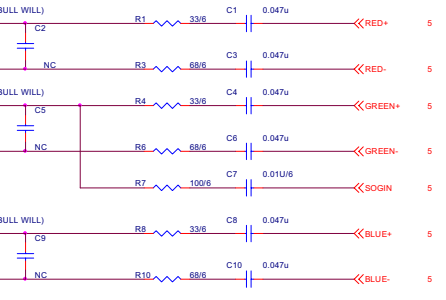
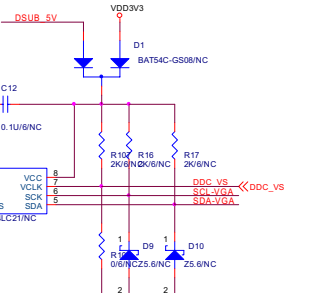
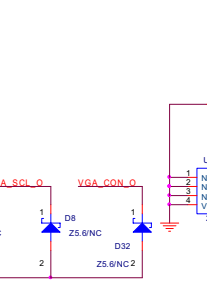
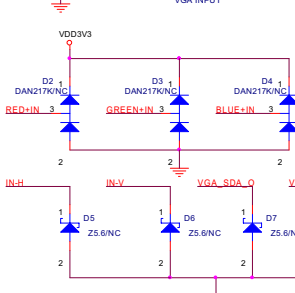
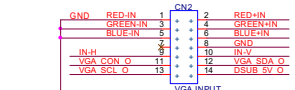
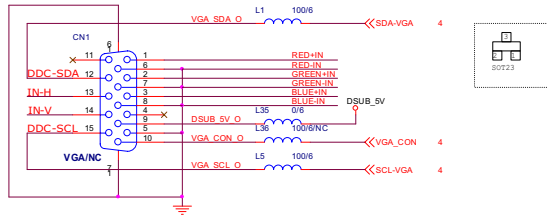

PROJECT : L5T
Quanta Computer Inc.

Title: **VGA AND DVI INPUT**

Sub: Document Number	VGA AND TMSD INPUT
Date: Monday, March 01, 2004	Sheet 3 of 7

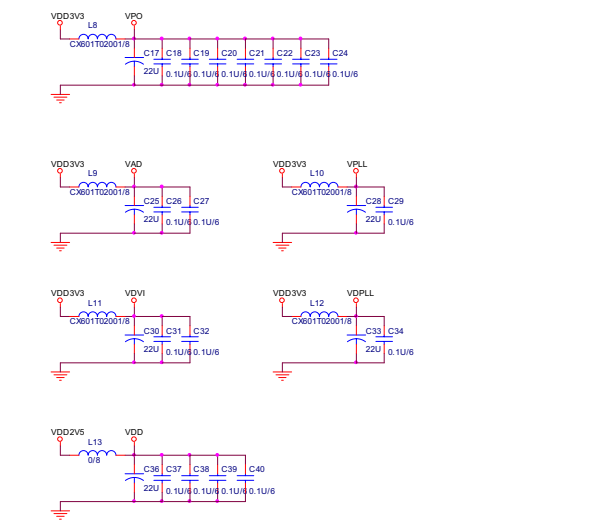
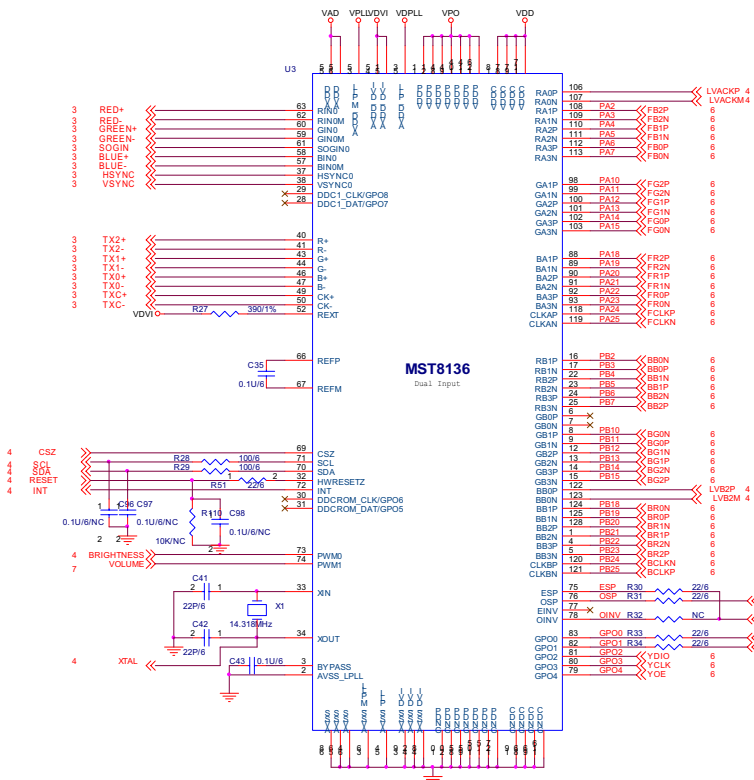

PROJECT : L5T
Quanta Computer Inc.

Title		MST8116/8136A	
Size	Document Number	MST8011A	Rev B
Date	Friday, February 27, 2004	Sheet	4 of 7

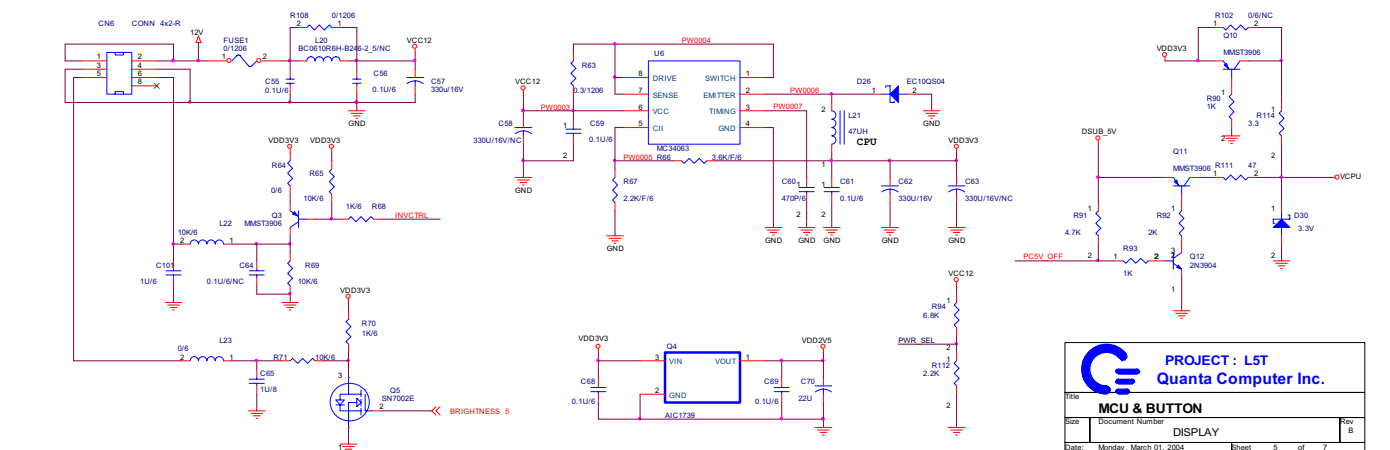
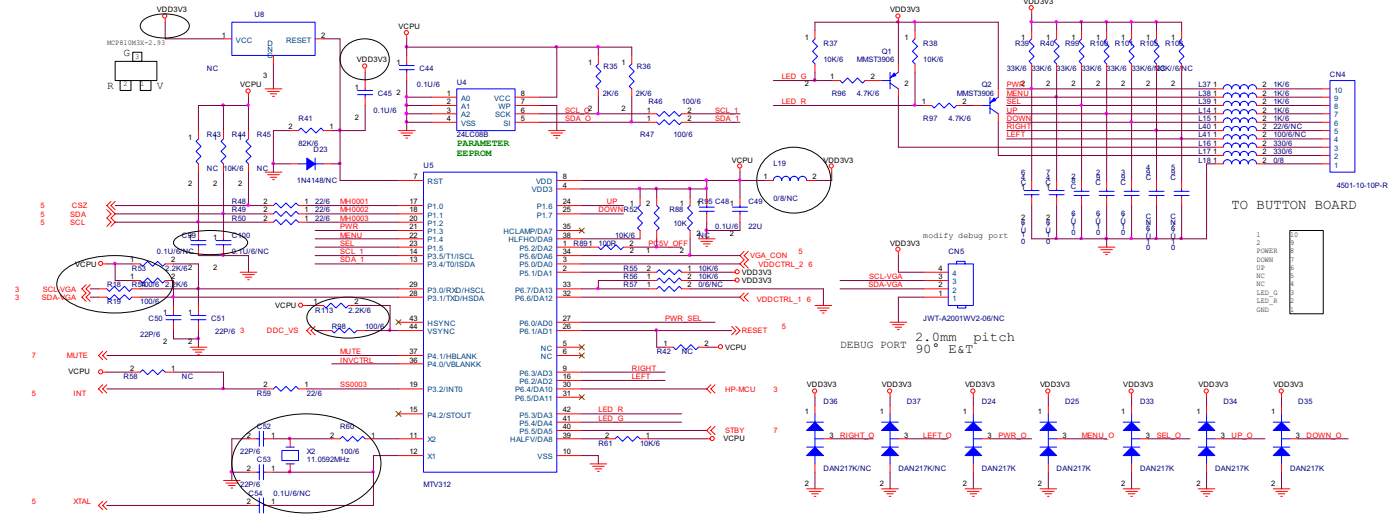

PROJECT : L5T
Quanta Computer Inc.

Title		MCU & BUTTON	
Size	Document Number	DISPLAY	Rev B
Date	Monday, March 01, 2004	Sheet	5 of 7

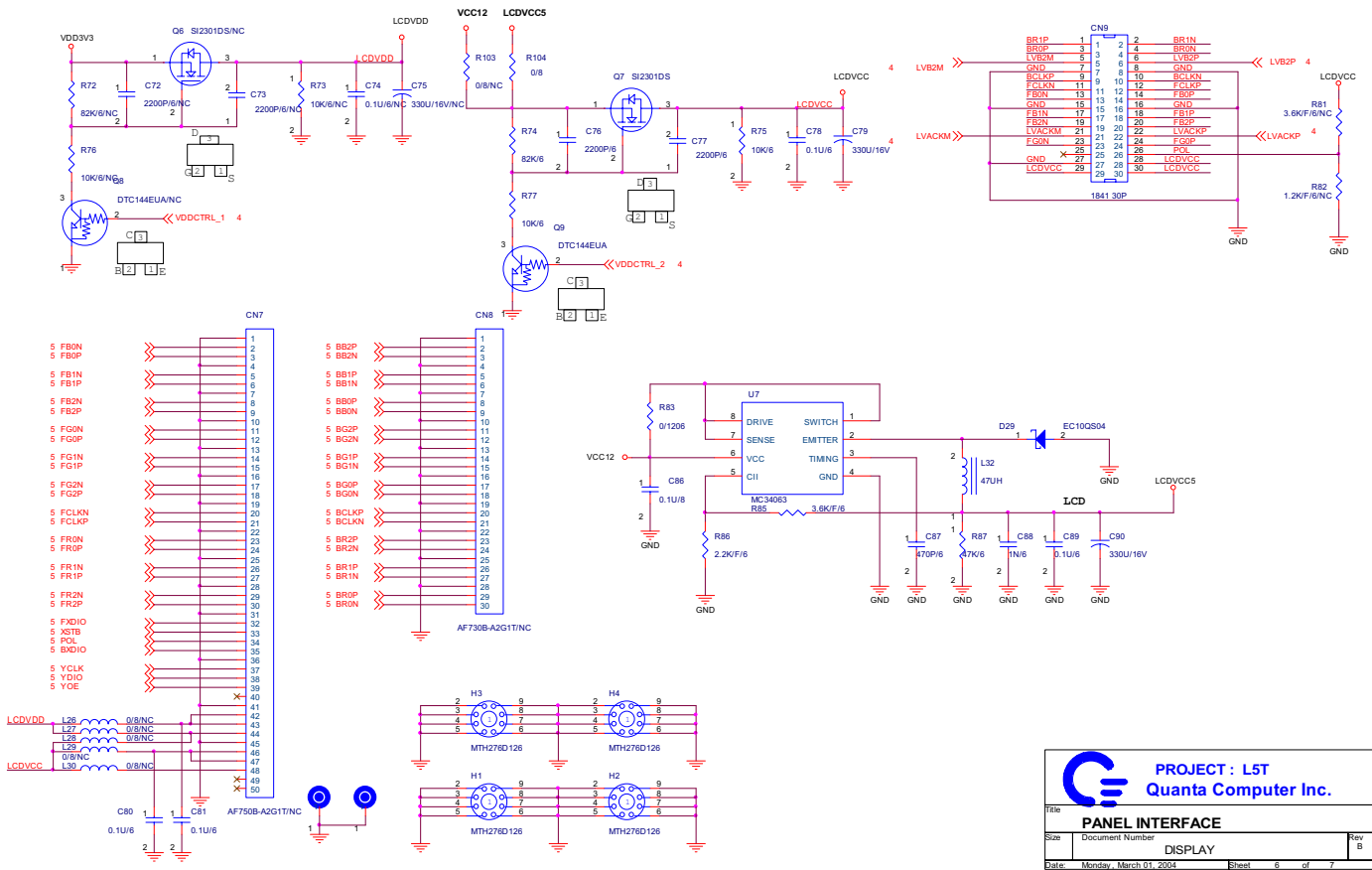

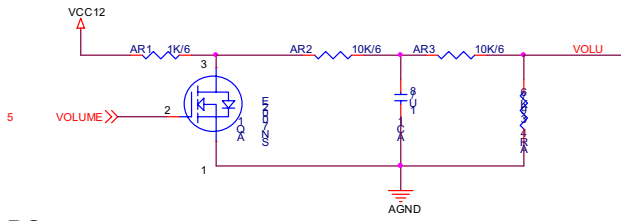

PROJECT: L5T
Quanta Computer Inc.

Title		PANEL INTERFACE	
Size	Document Number	DISPLAY	
Date:	Monday, March 01, 2004	Sheet	6 of 7

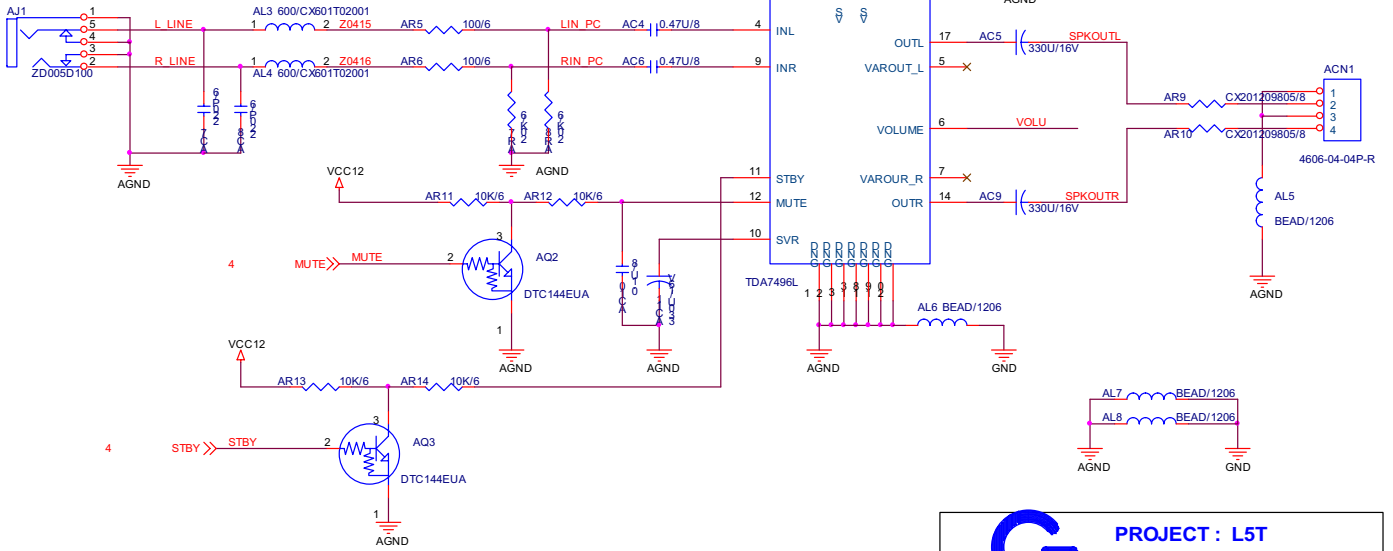

**PC
AUDIO-IN**



		PROJECT : L5T Quanta Computer Inc.	
Title			
Audio			
Size	Document Number	DISPLAY	Rev B
Date:	Friday, February 27, 2004	Sheet	7 of 7