

CONFIDENTIAL



TFT-LCD MONITOR

Chassis	Model
GH17A*	171N
GH17L*	171s
(GH17L***J/***)	

SERVICE *Manual*

TFT-LCD MONITOR

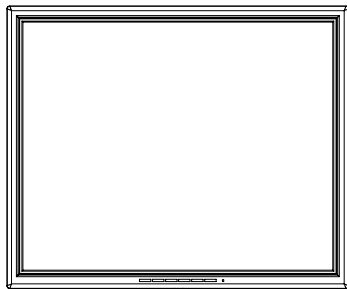

GH17A*

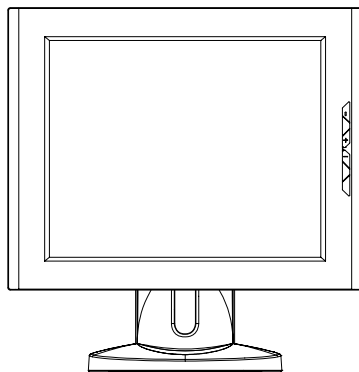

GH17L***J/***

CONTENTS

1. Precautions
2. Product Specifications
3. Disassembly & Reassembly
4. Alignments & Adjustments
5. Troubleshooting
6. Exploded View & Parts List
7. Electrical Parts List
8. Block Diagram
9. Wiring Diagram
10. Schematic Diagrams
11. Panel Description

4 Alignments and Adjustments

This section of the service manual explains how to use the RS232 JIG.
This function is needed when AD Board Change and program memory (IC110) change.

4-1 Required Equipment

The following equipment is necessary for adjusting the monitor:

- Computer with Windows 95[®], Windows 98[®], or Windows NT[®].
- RS232 JIG.

4-2 RS232 Jig Setup

1. Install Hyper Terminal program from windows system.
2. Configure Baud rate to 19200, select appropriate COM port.
3. Make the Hardware setup as per figure shown.

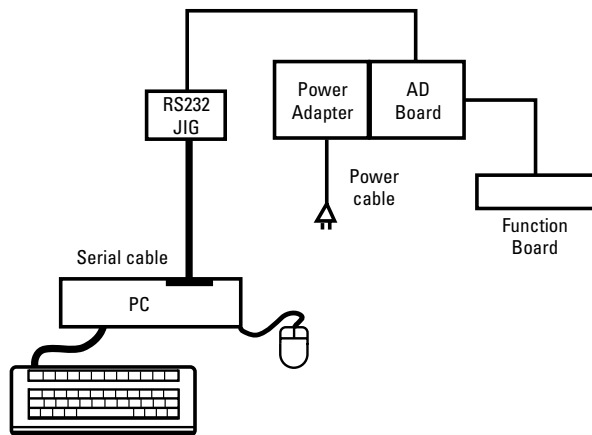

Figure 4-1.

4. Establish the connection by selecting "Connect" from hyper Terminal.
5. Power on the board, now you see messages in the application window.
If no messages than check for 1, 2 and 3 again.

Message :

Gogh 17*** fw. copyright (c) 2000, 2001 Sage.

Date : ***. **. **.

Chip ID : b1.

Panel : Samsung 17 SXGA.

4-3 Changing Board

Before replacing the AD Board, read all Panel information data by using RS232 JIG and hyper terminal.

1. Type character `B`.

Service Menu for Gogh 17 Model.

1. Read.
2. Modify upper Back Light Value.
3. Modify Lower back Light Value.
4. Modify Panel On Time Value.
5. Exit Service Menu

Enter 1

Upper Backlight Time Expired (in hours) : ***

Lower Backlight Time Expired (in hours) : ***

Panel On Time (in hours) : ***

Please note down these values. Than change to new board. Execute the command `B`, read the values. You will see these are set to default values. Change the values to the recorded values. Exit the service menu by `B` command.

2. Color Auto Adjustment

After function `1`. Assemble the monitor.

And display 16-Gray pattern or black and white mixed pattern. Then push "Exit", "-" and "+" key of function same time.

During normal execution of Auto Algorithm the screen image may changed.

4-4 Program memory (IC110) change

Follow same method as changing Board (4-3).

Memo

5 Troubleshooting

- Notes:**
- Before troubleshooting, setup the PC's display as below.
 - Resolution: 1280 x 1024
 - H-frequency: 64 kHz
 - V-frequency: 60 Hz
 - If no picture appears, make sure the power cord is correctly connected.
 - If you push and hold the EXIT button for more than 5 seconds, the monitor automatically turns back to the factory preset.

5-1-1 No Power

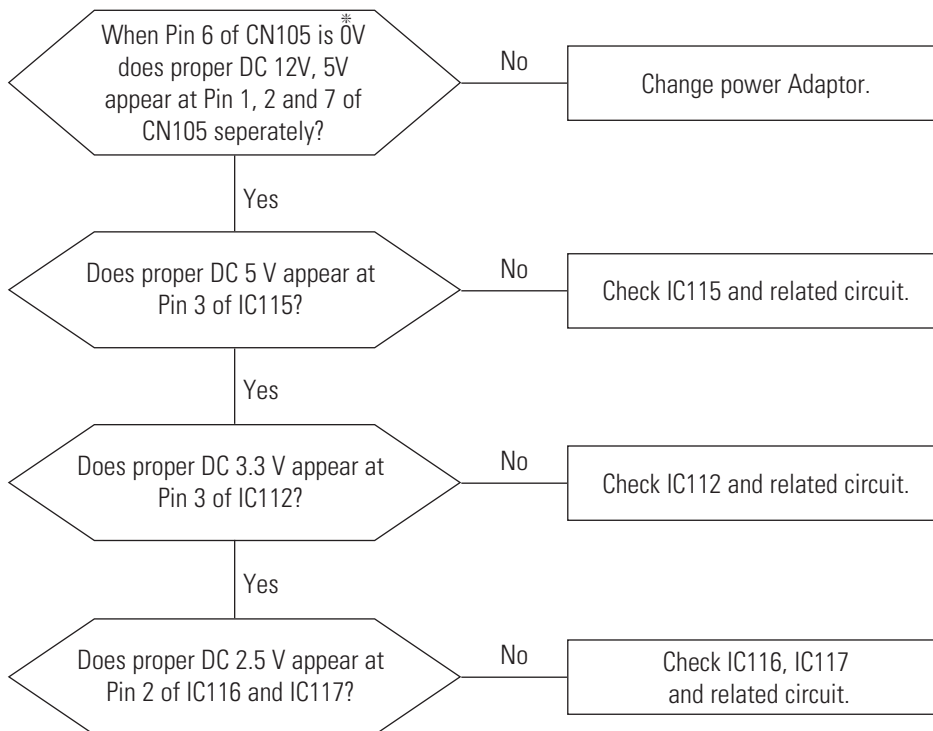

* 0V means power on state.

5-1-2 No Power

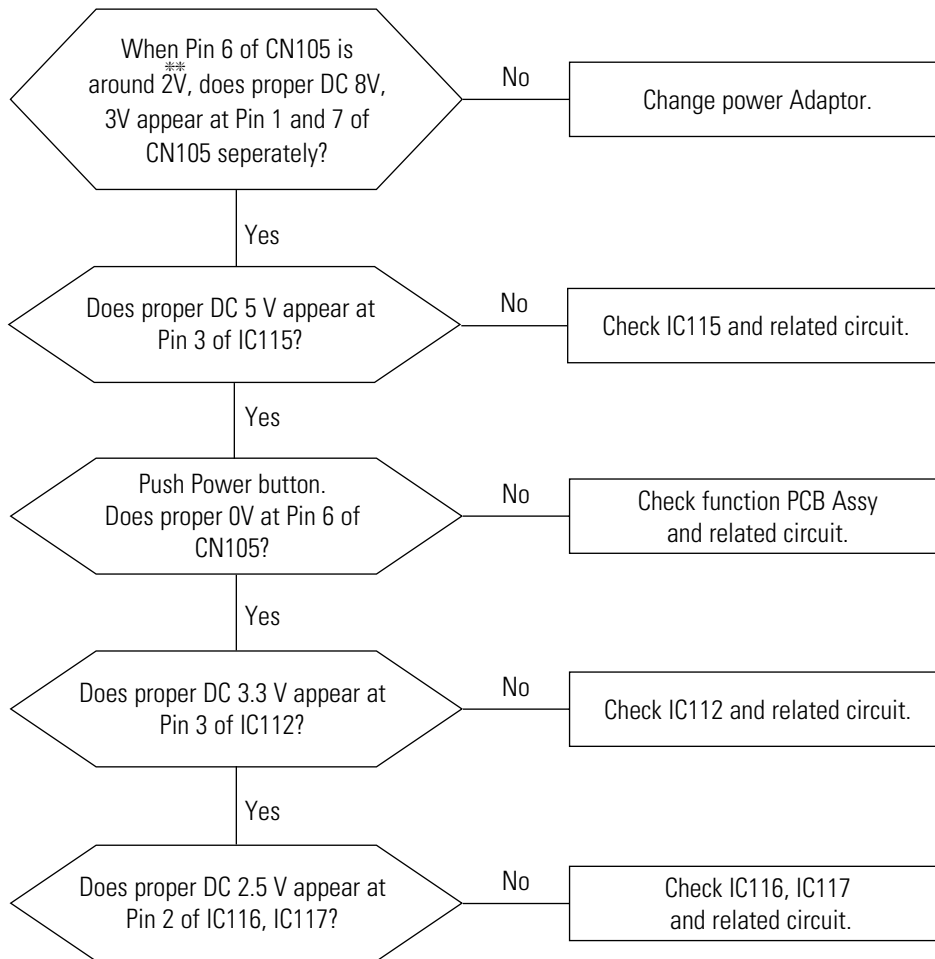

※※ 2V means soft power off or DPMS state.

5-2 No Video

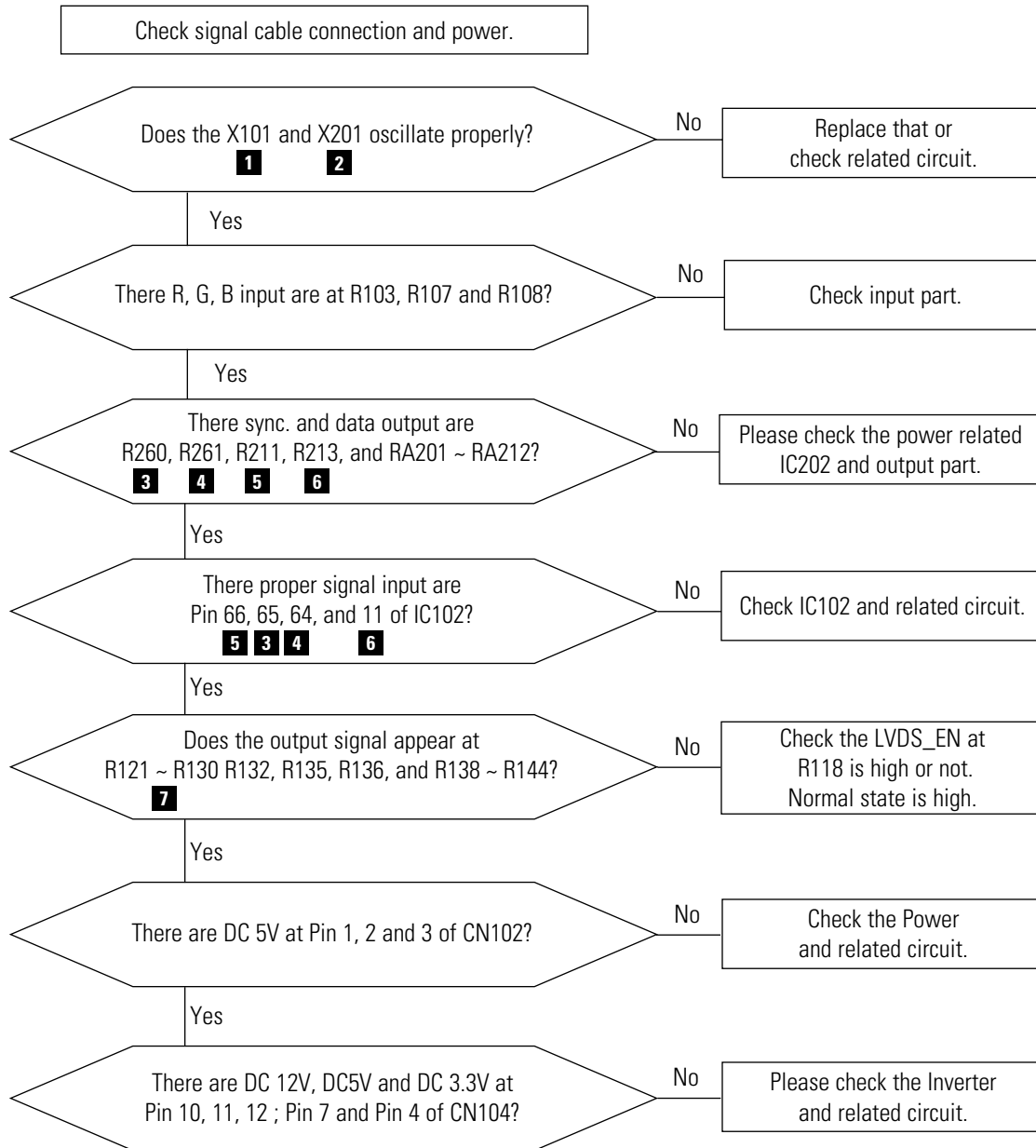

WAVEFORMS

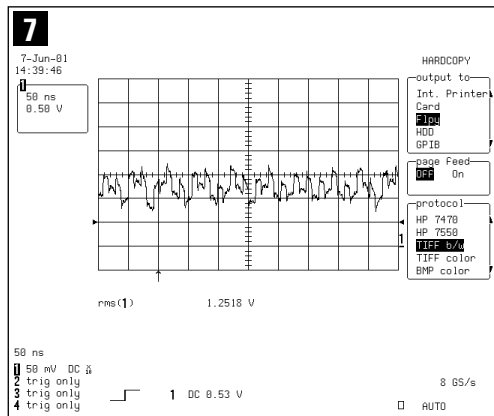
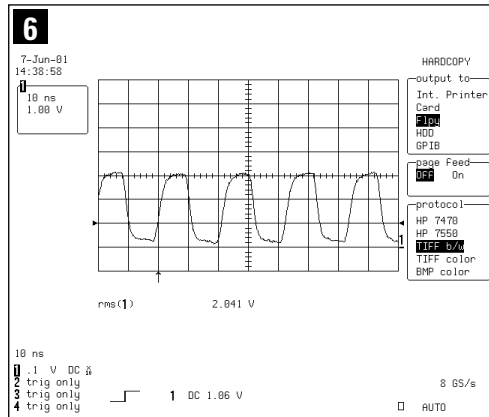
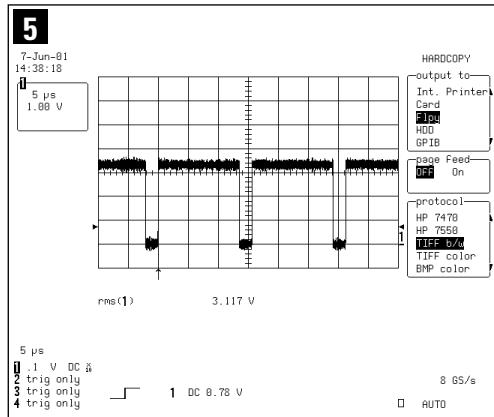
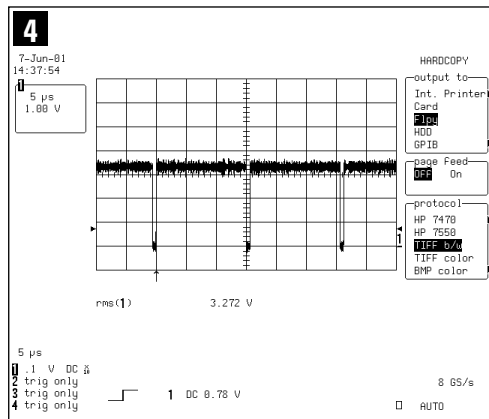
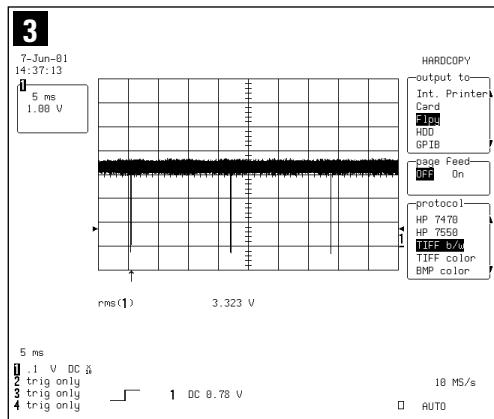
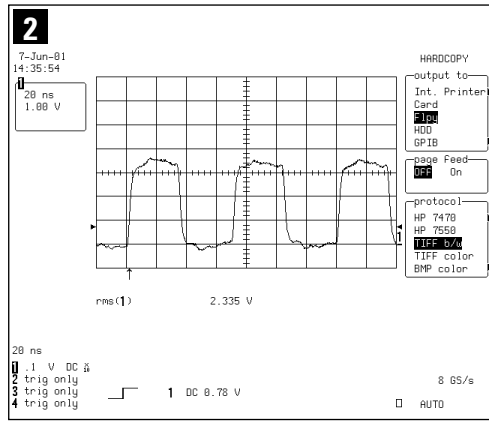
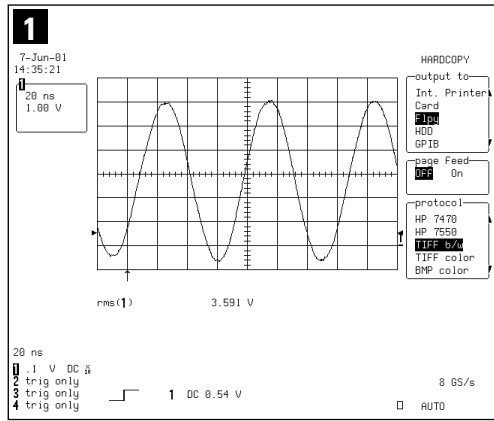

8 Block Diagram

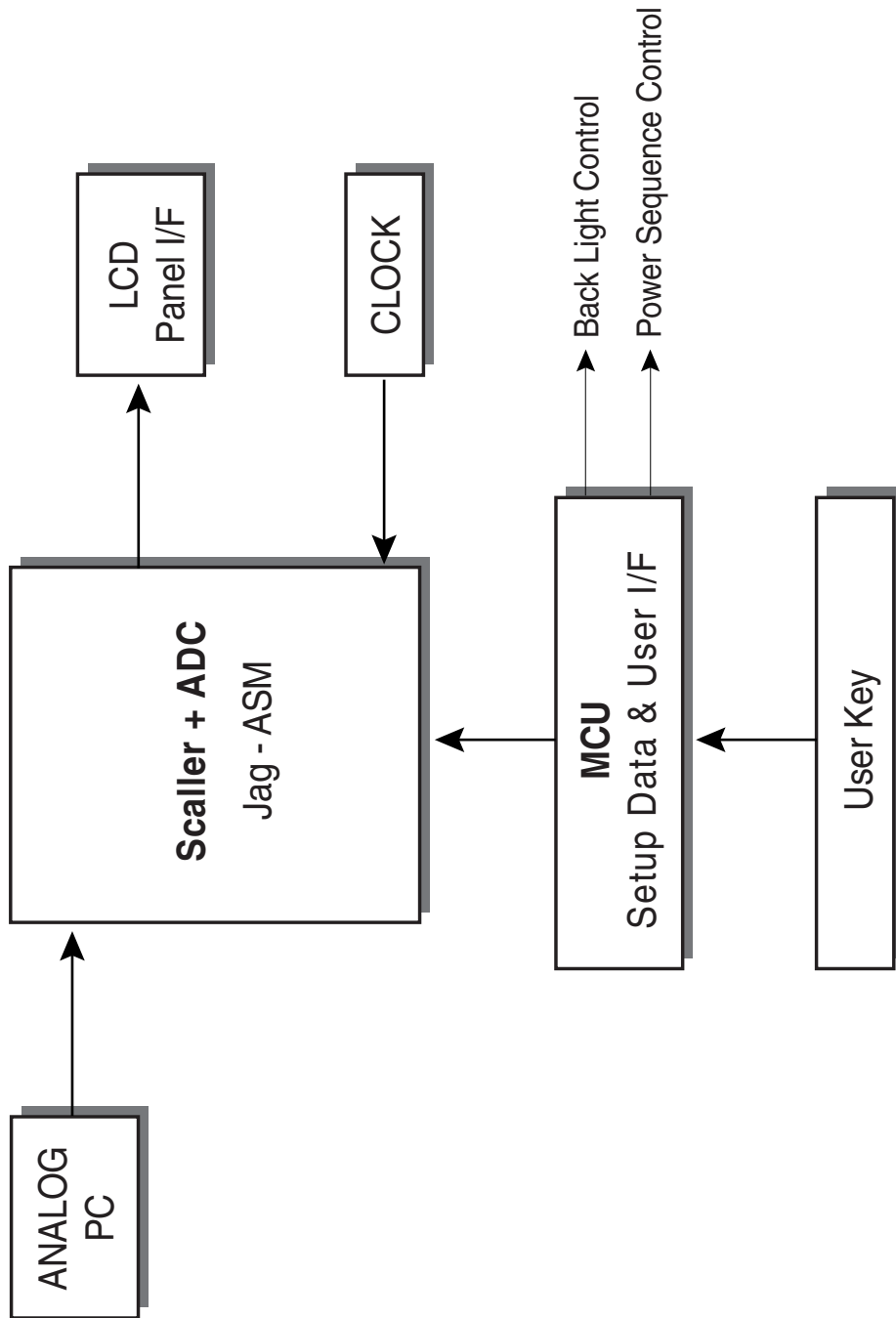

Memo

9 Wiring Diagram

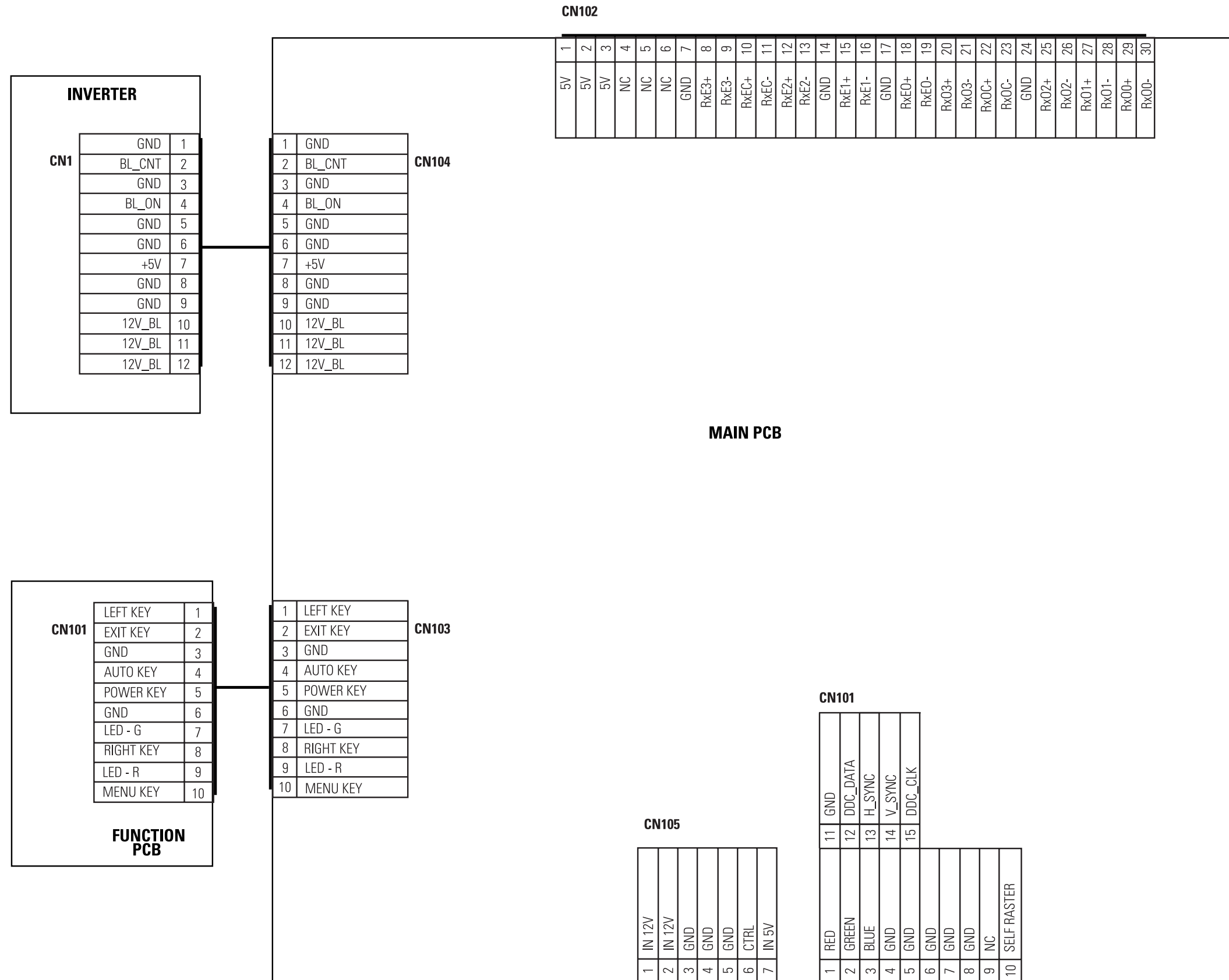

Memo

10 Schematic Diagrams

10-1 Main Part Schematic Diagram

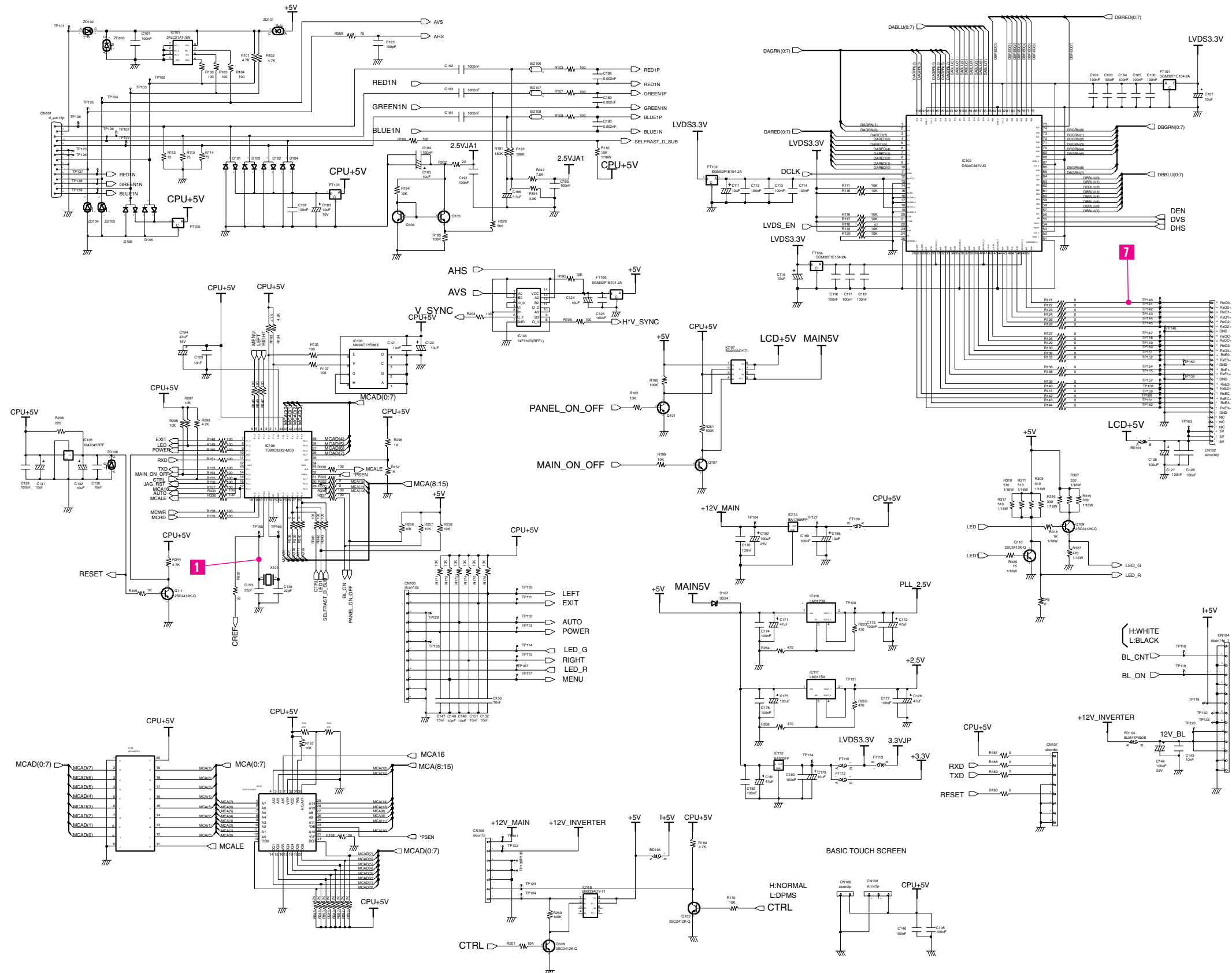

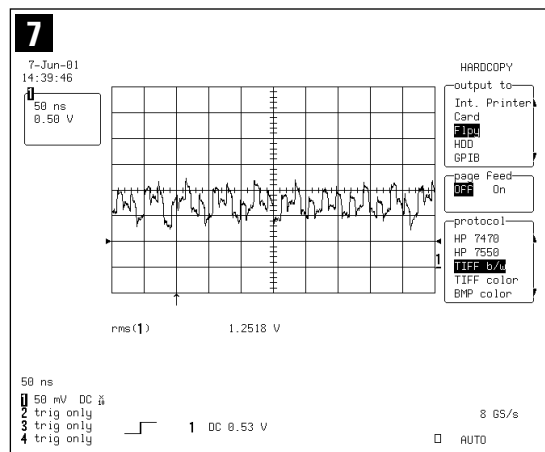
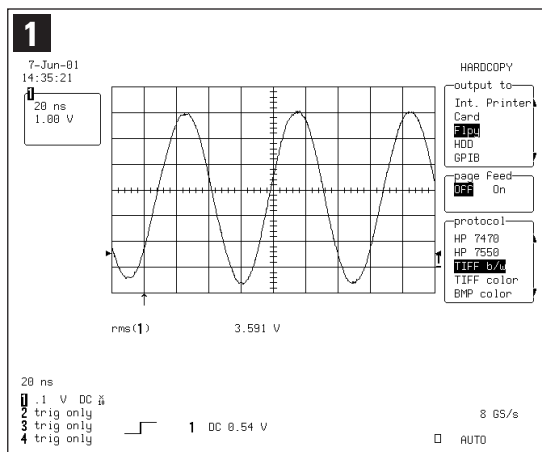

10-2 Main Part Schematic Diagram

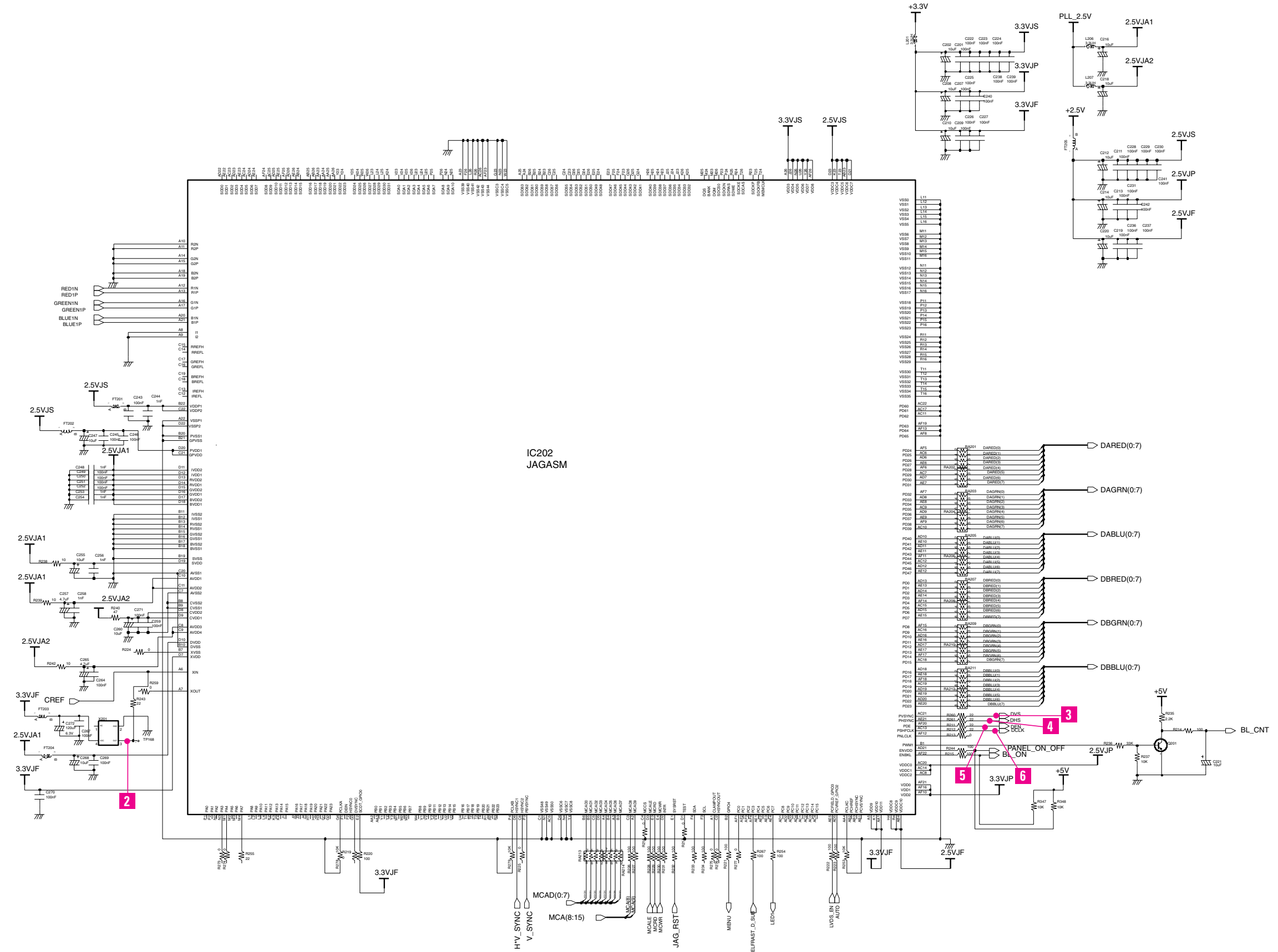

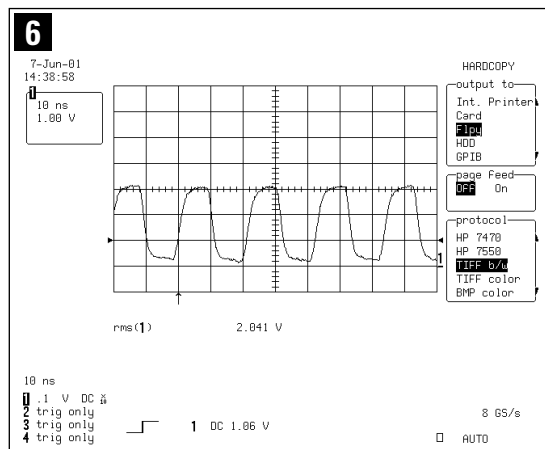
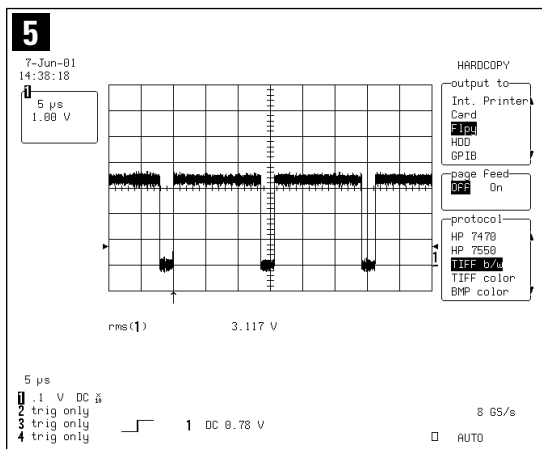
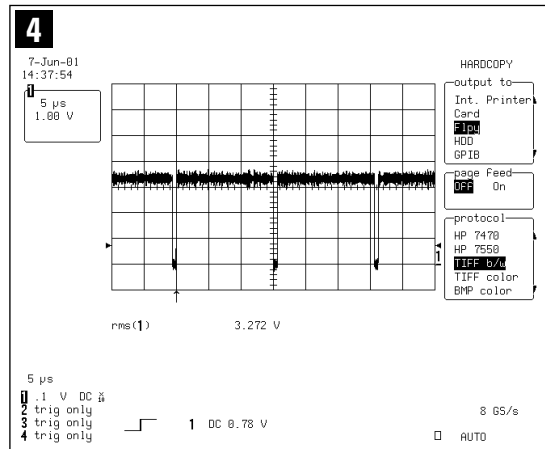
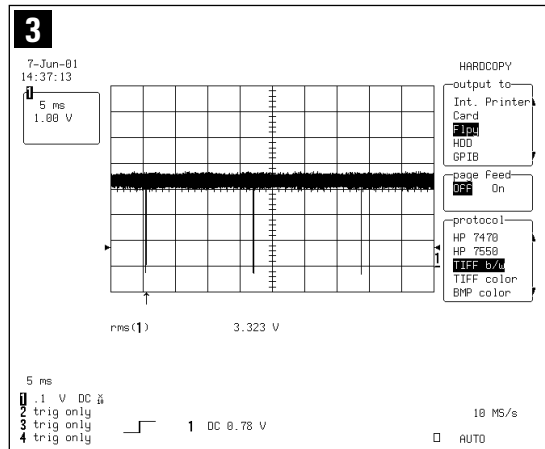
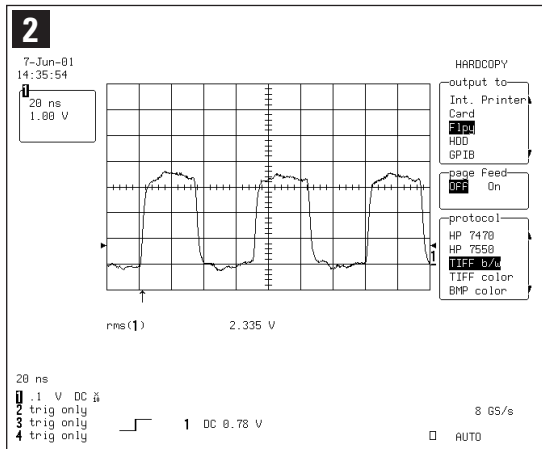



Samsung Electronics Co.,Ltd.

416, Maetan-3Dong, Paldal-Gu, Suwon City, Kyungki-Do, Korea.

Printed in Korea

P/N : BN82-00073C-00

<http://www.samsungmonitor.com> (SyncMaster Worldwide)

<http://www.samsung-monitor.com> (SyncMaster USA)

<http://www.sec.co.kr/monitor> (Korea)