

# 7 Block Diagram

## 7-1 150MB

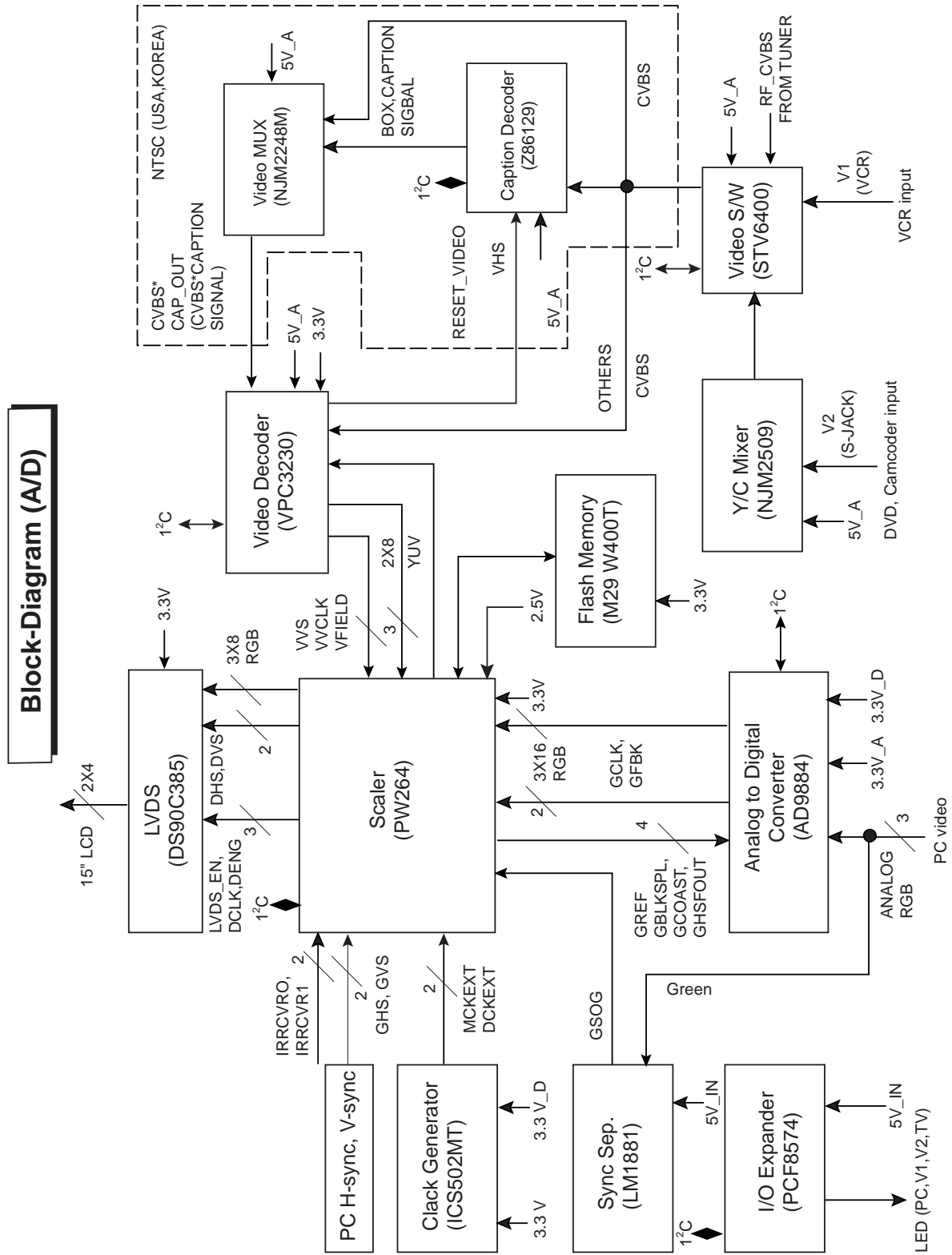

**Block-Diagram (Without Tuner)**

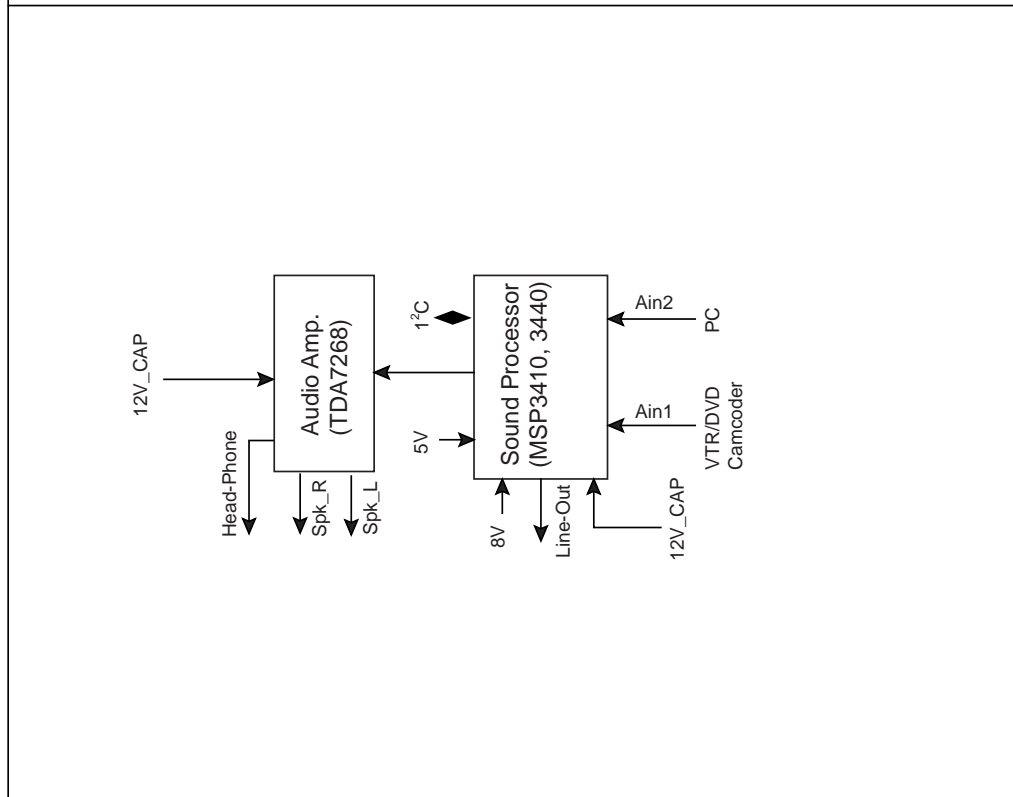

**Block-Diagram (POWER)**

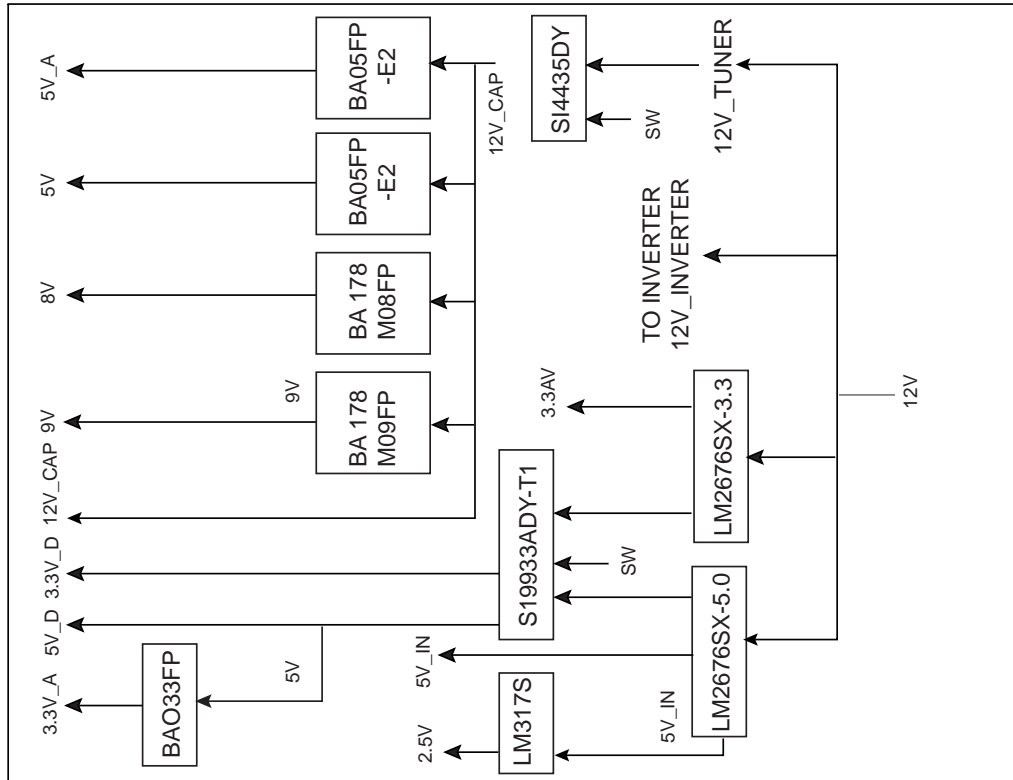

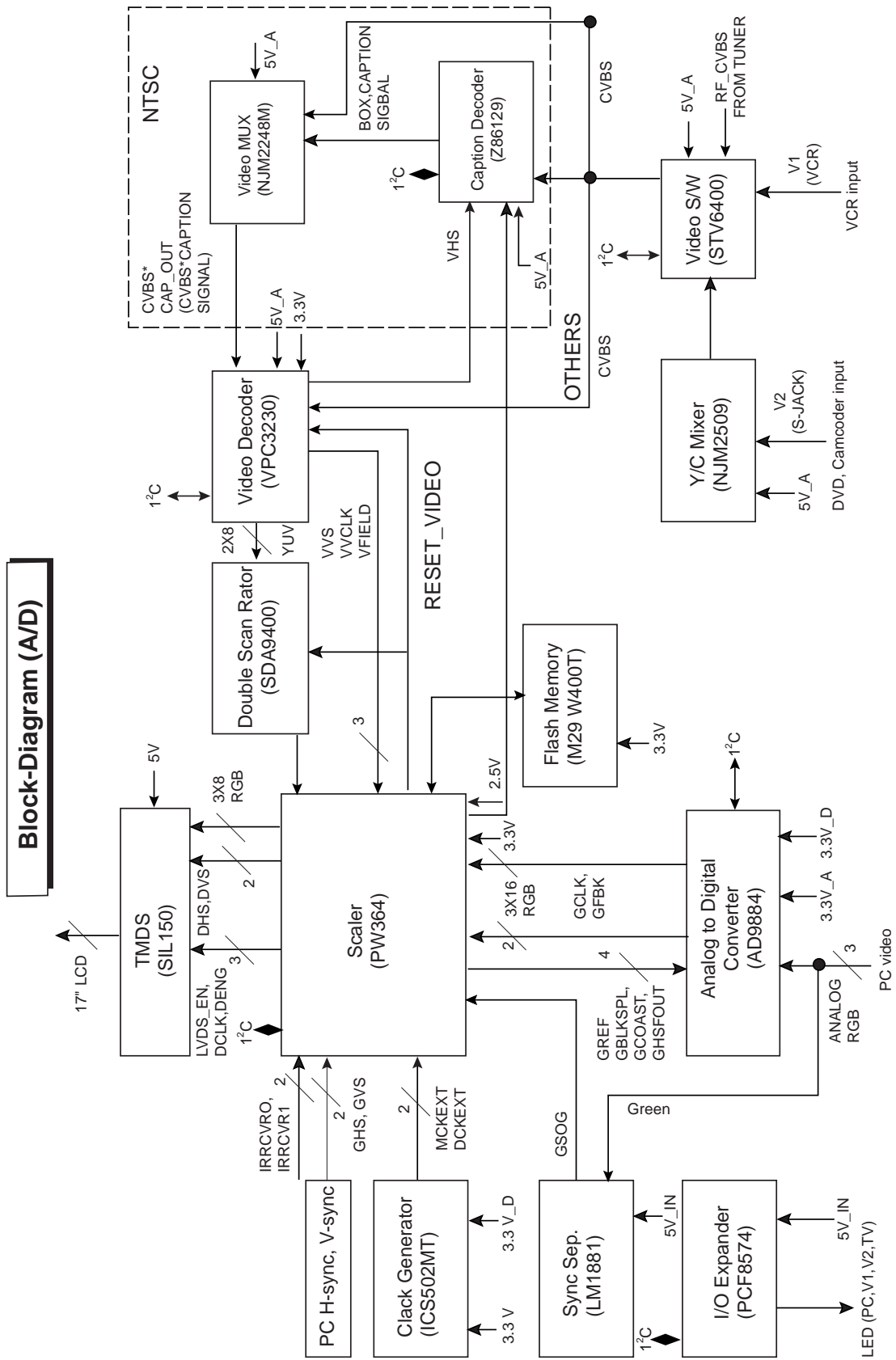

**Block-Diagram (Without Tuner)**

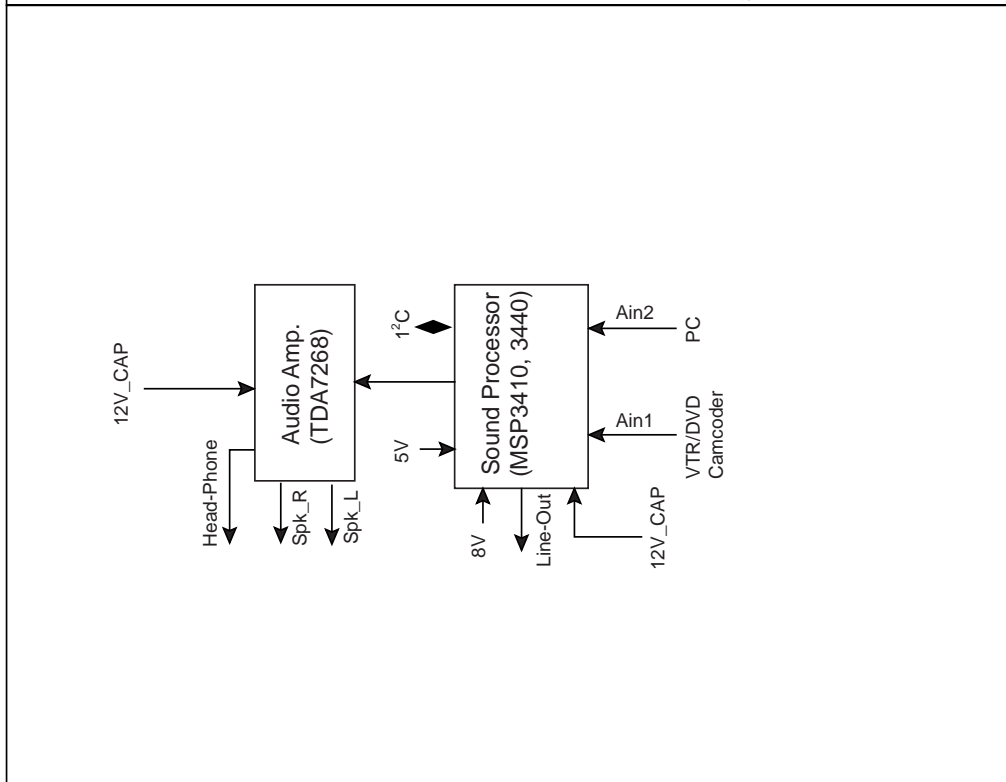

**Block-Diagram (POWER)**

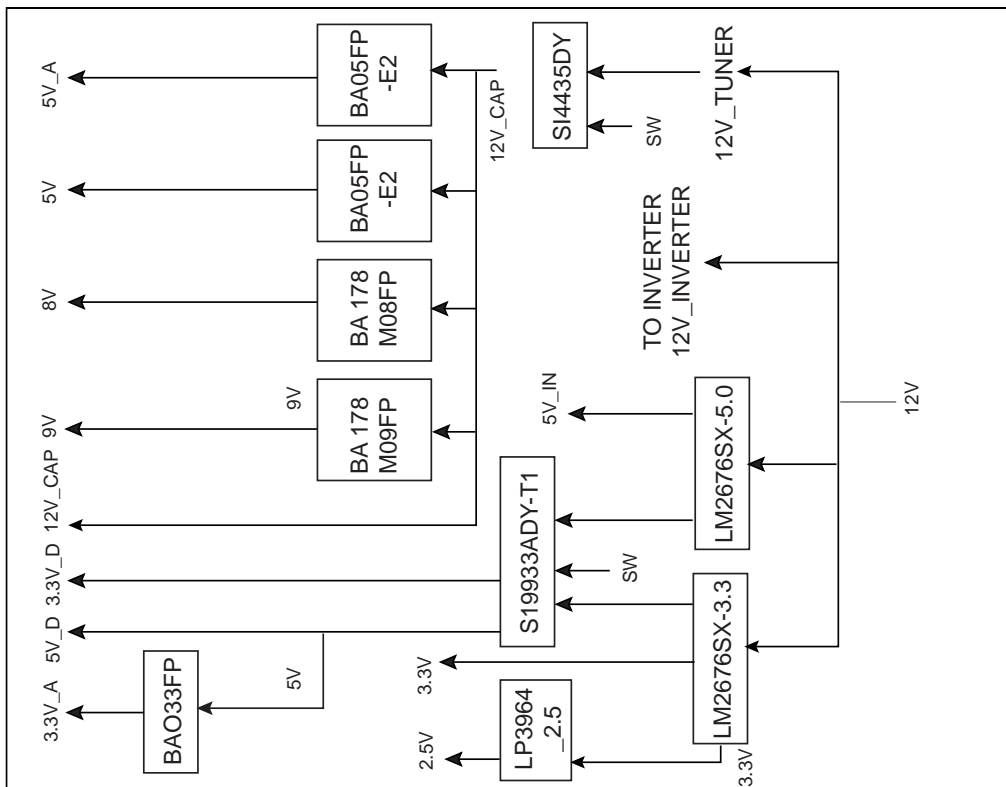

# 8 Wiring Diagram

8-1 150MB

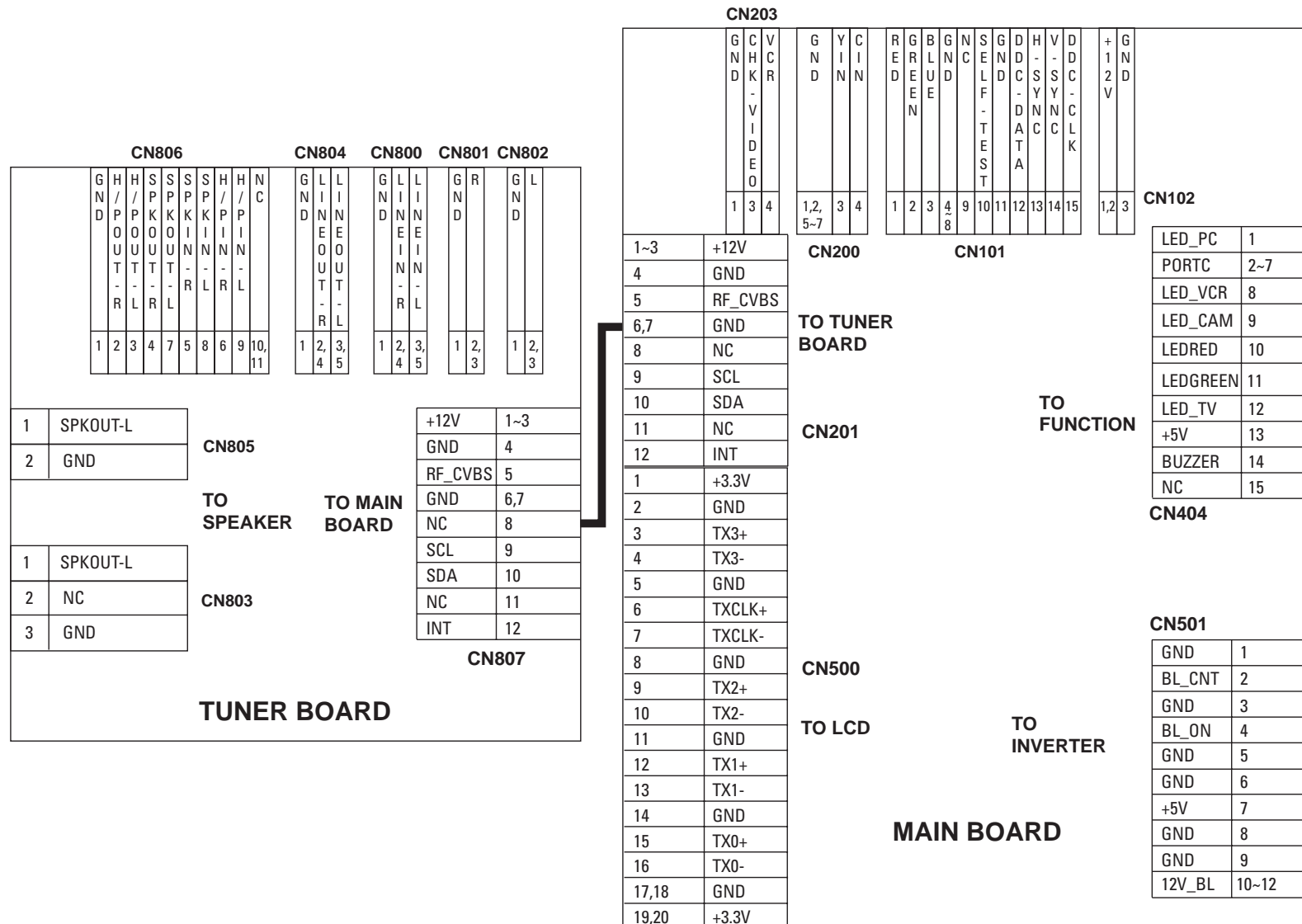

8-2 170MB

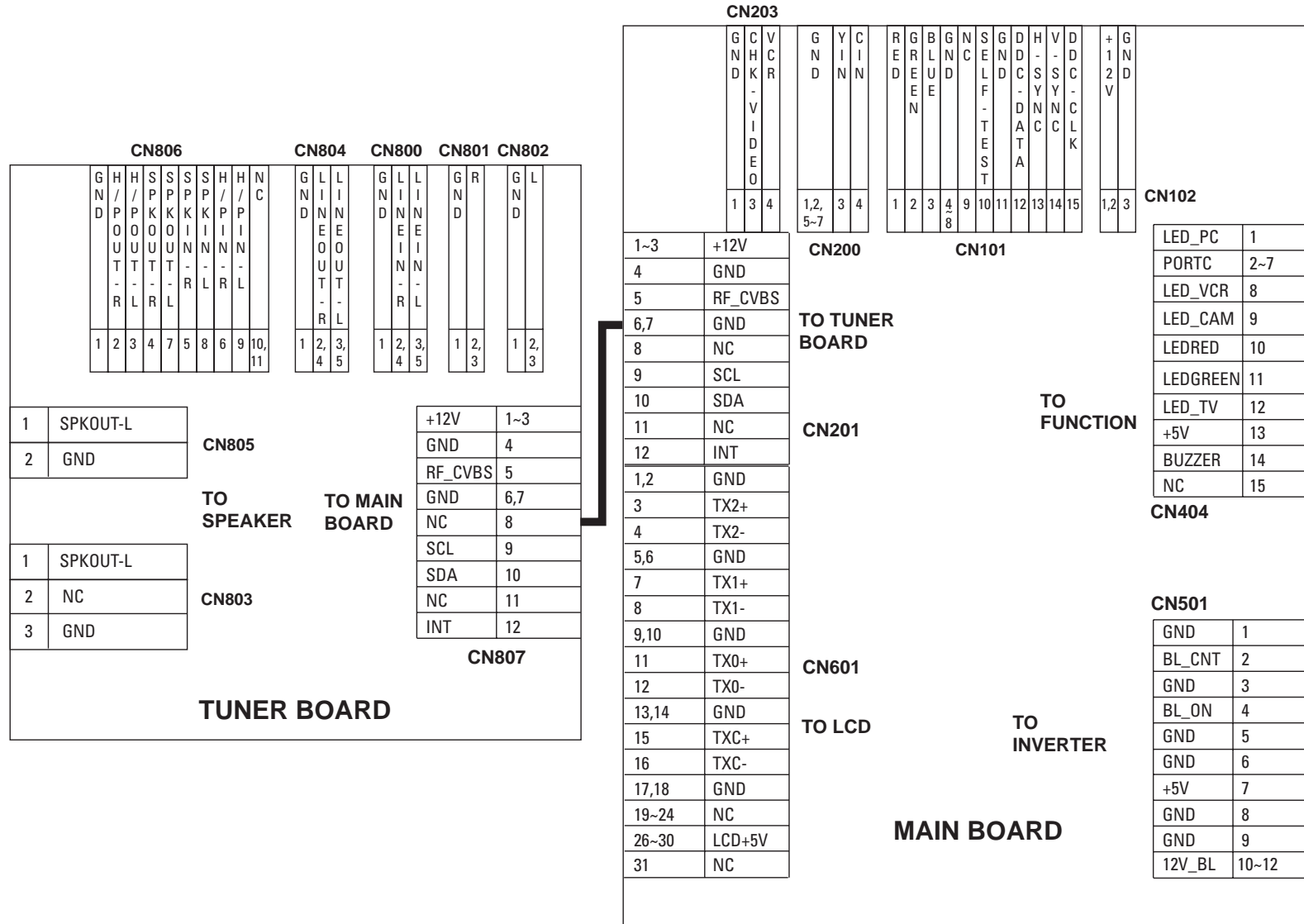

# 9 Schematic Diagram

## 9-1 ADC / PLL Part Schematic Diagram (150MB)

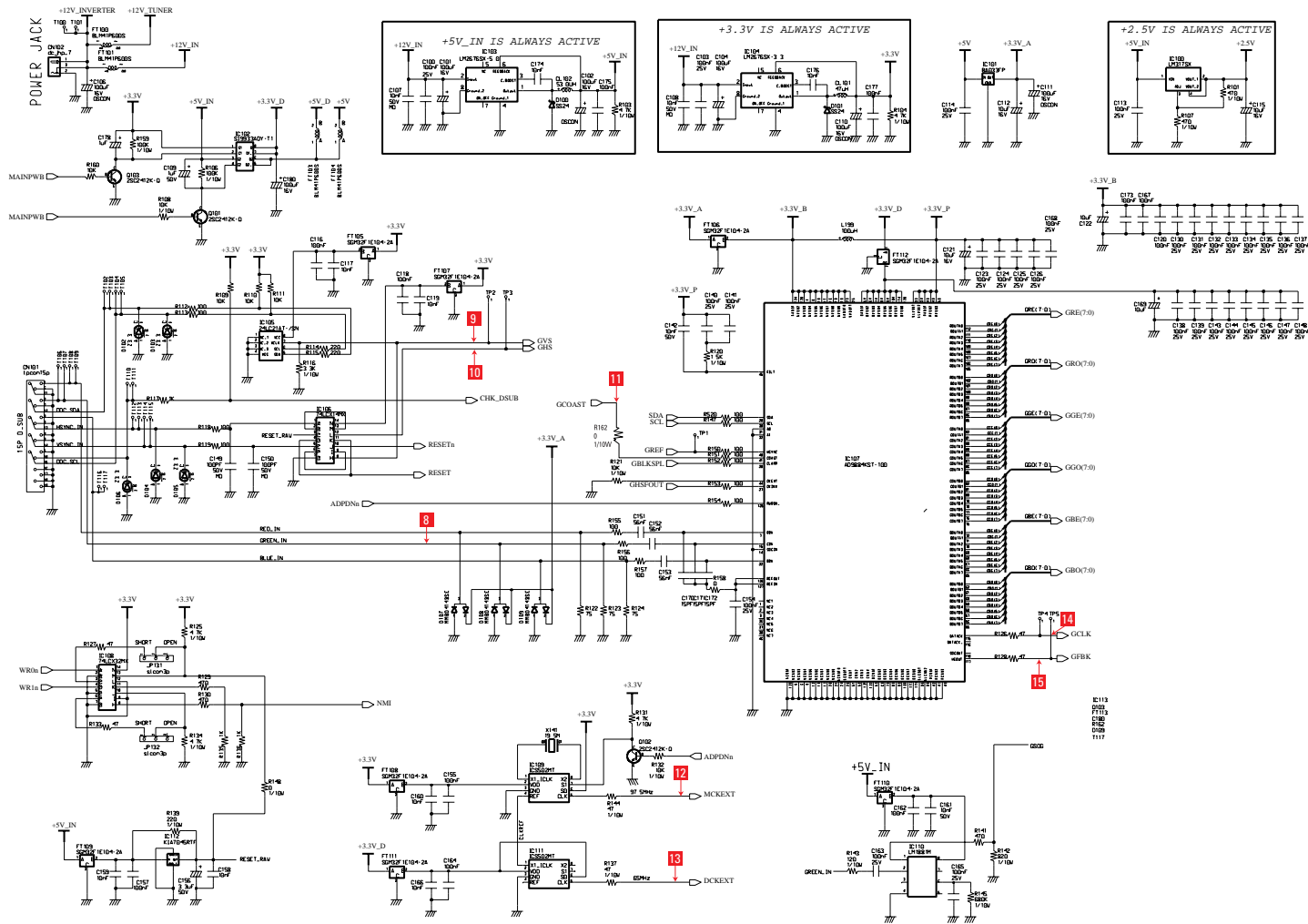

9-2 Video Decoder Part Schematic Diagram (150MB)

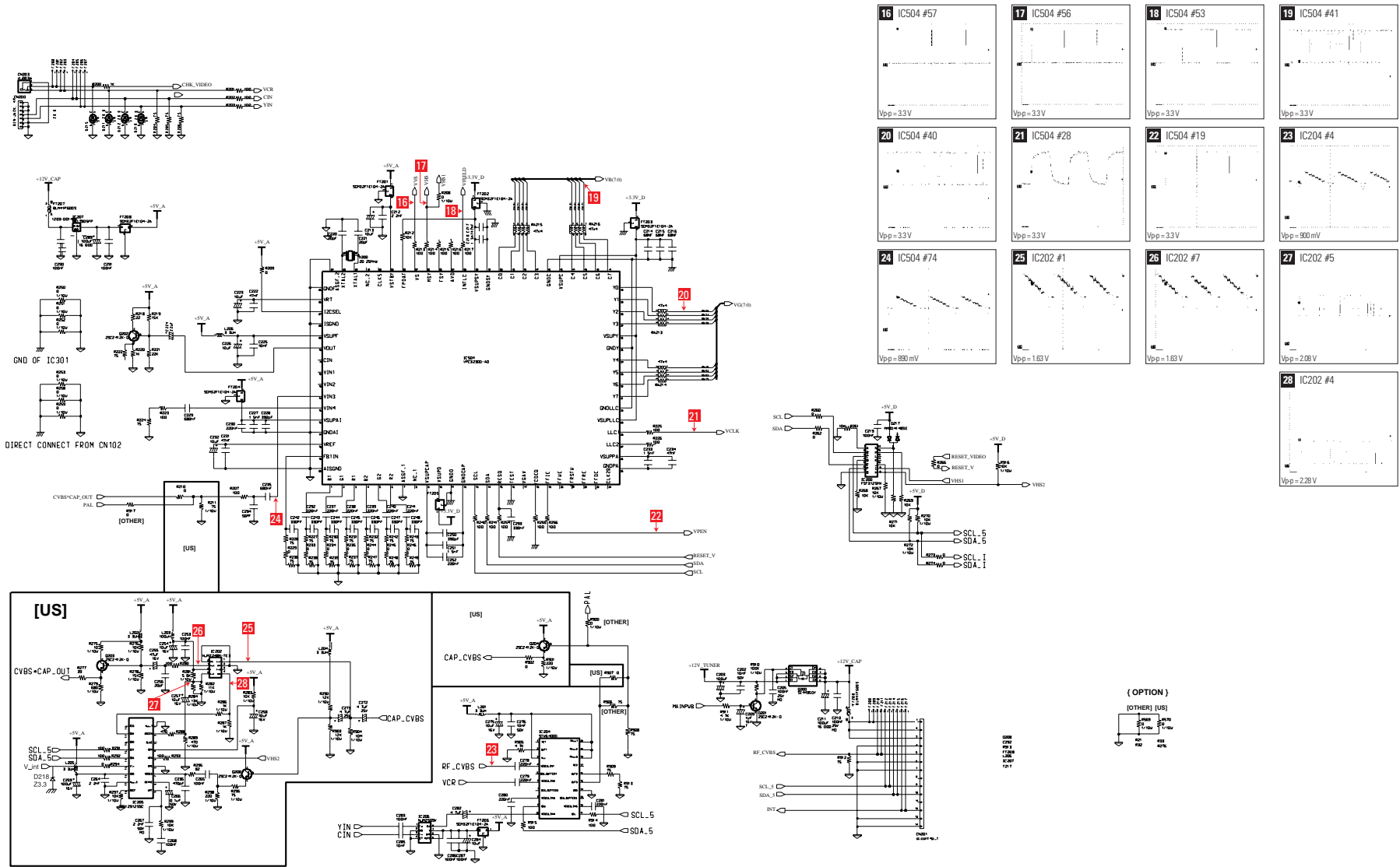



### 9-3 PW264 Part Schematic Diagram (150MB)

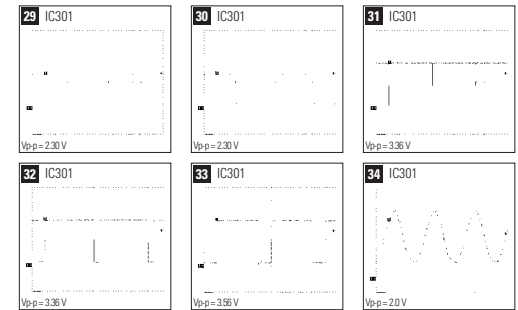
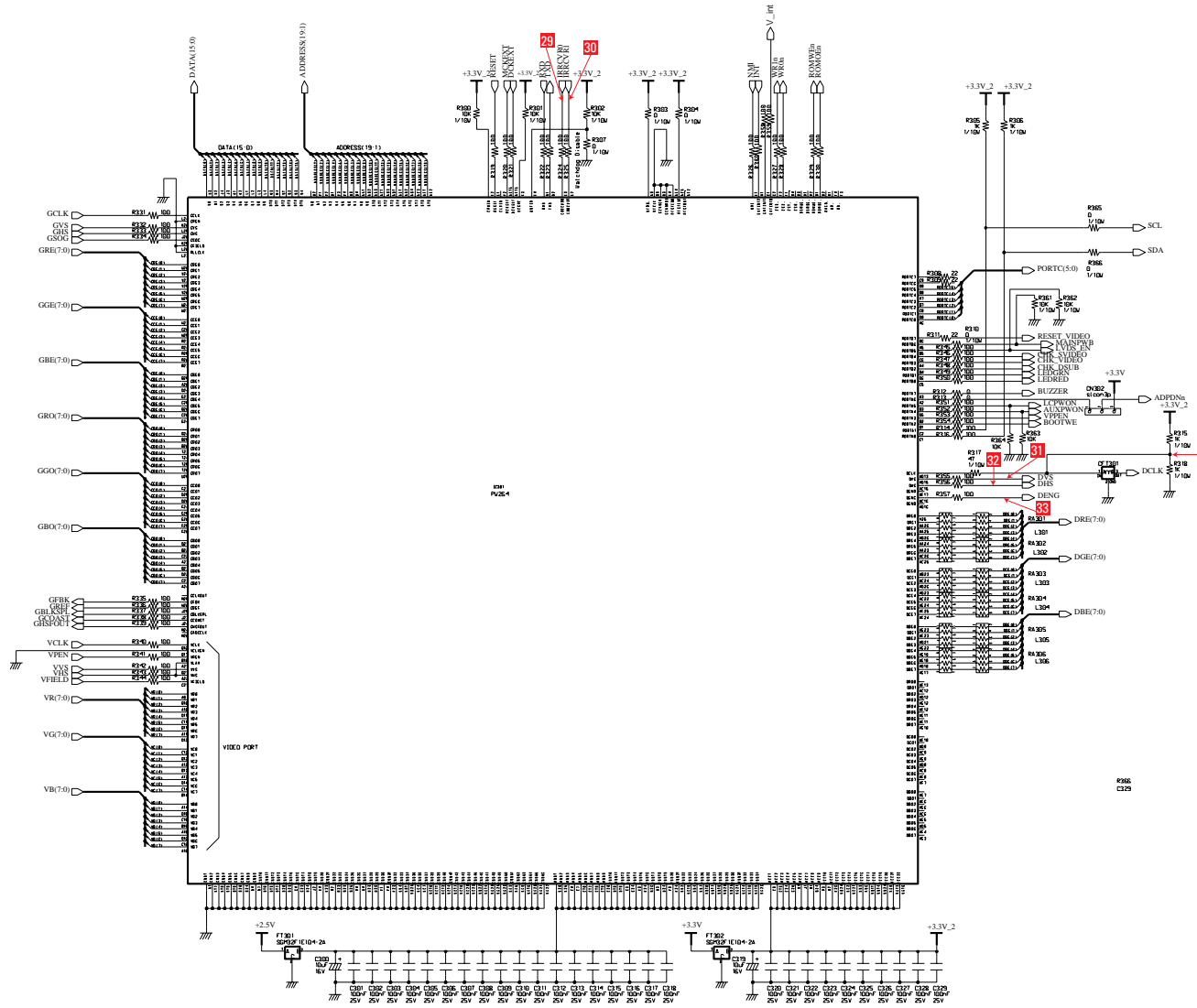

9-4 Memory Part Schematic Diagram (150MB)

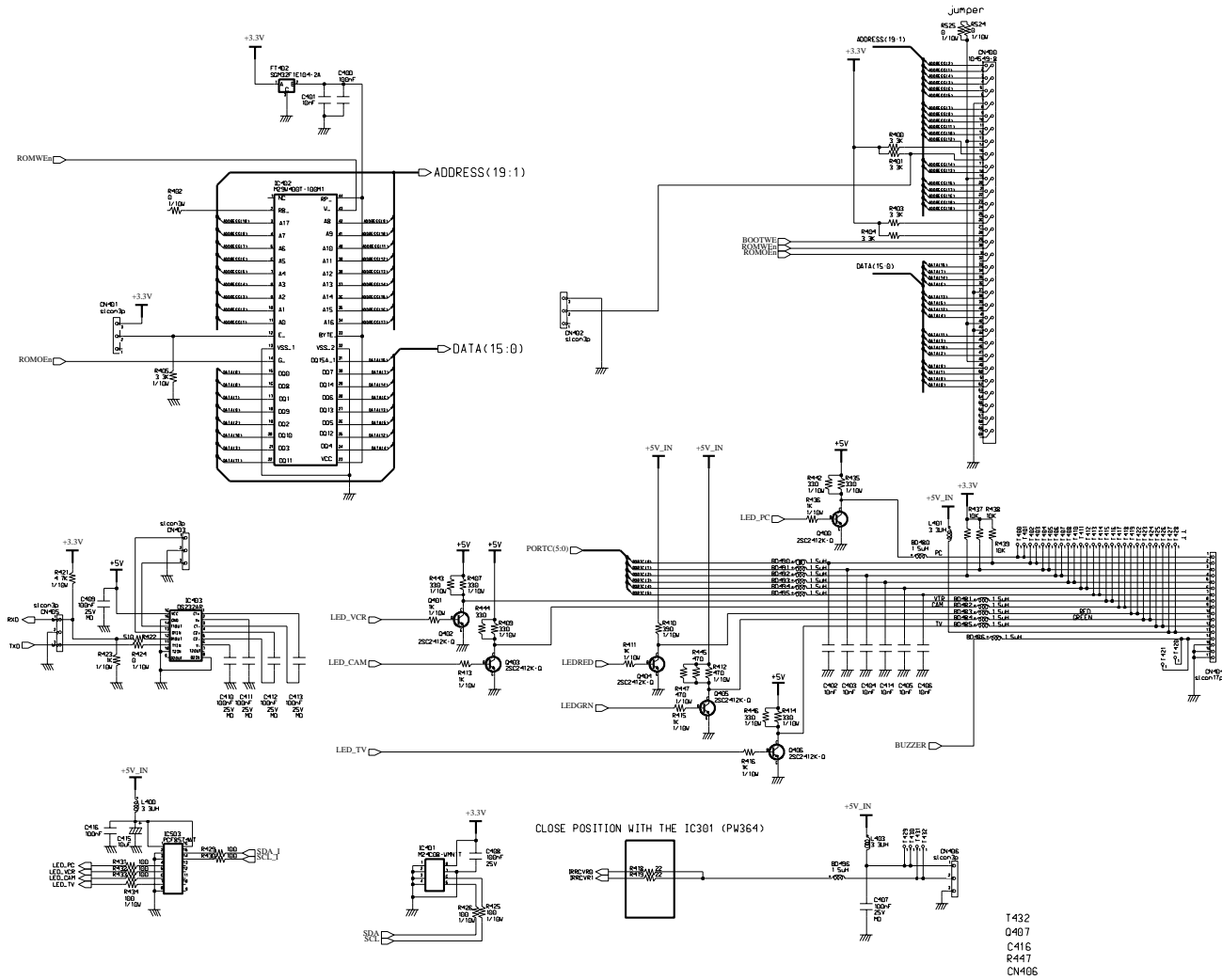

9-5 LVDS Part Schematic Diagram (150MB)

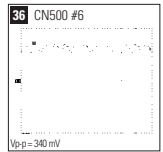
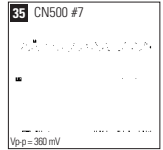
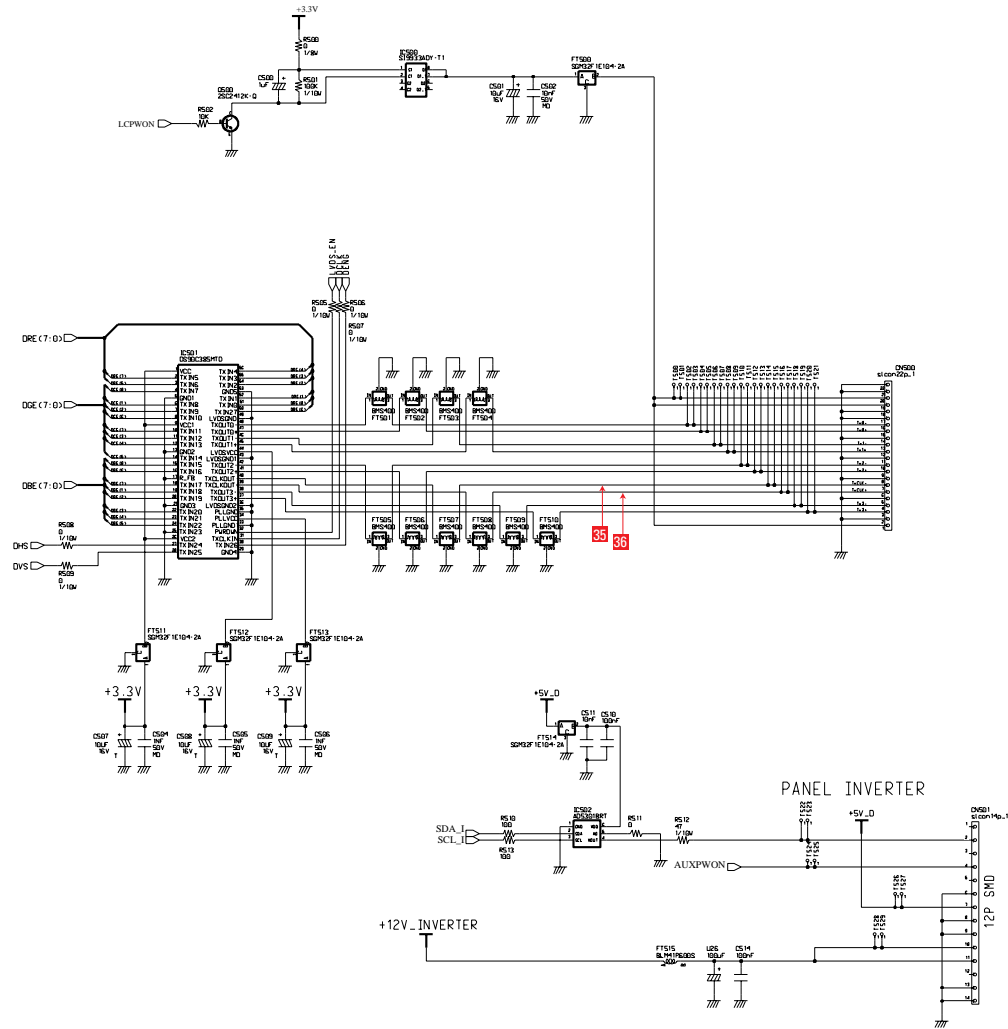

85 15  
85 14  
85 13  
85 12

9-6 Audio Part Schematic Diagram (150MB)

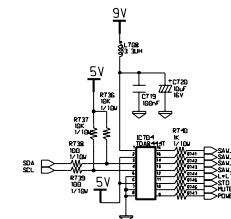
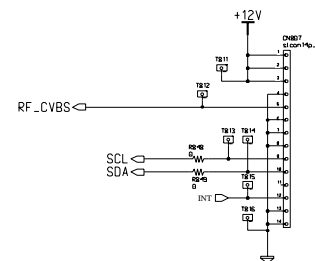
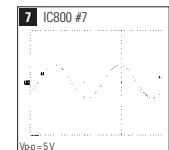
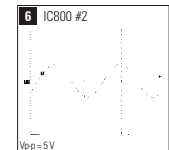
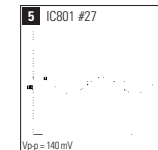
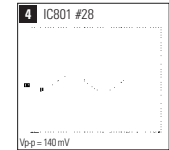
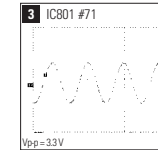
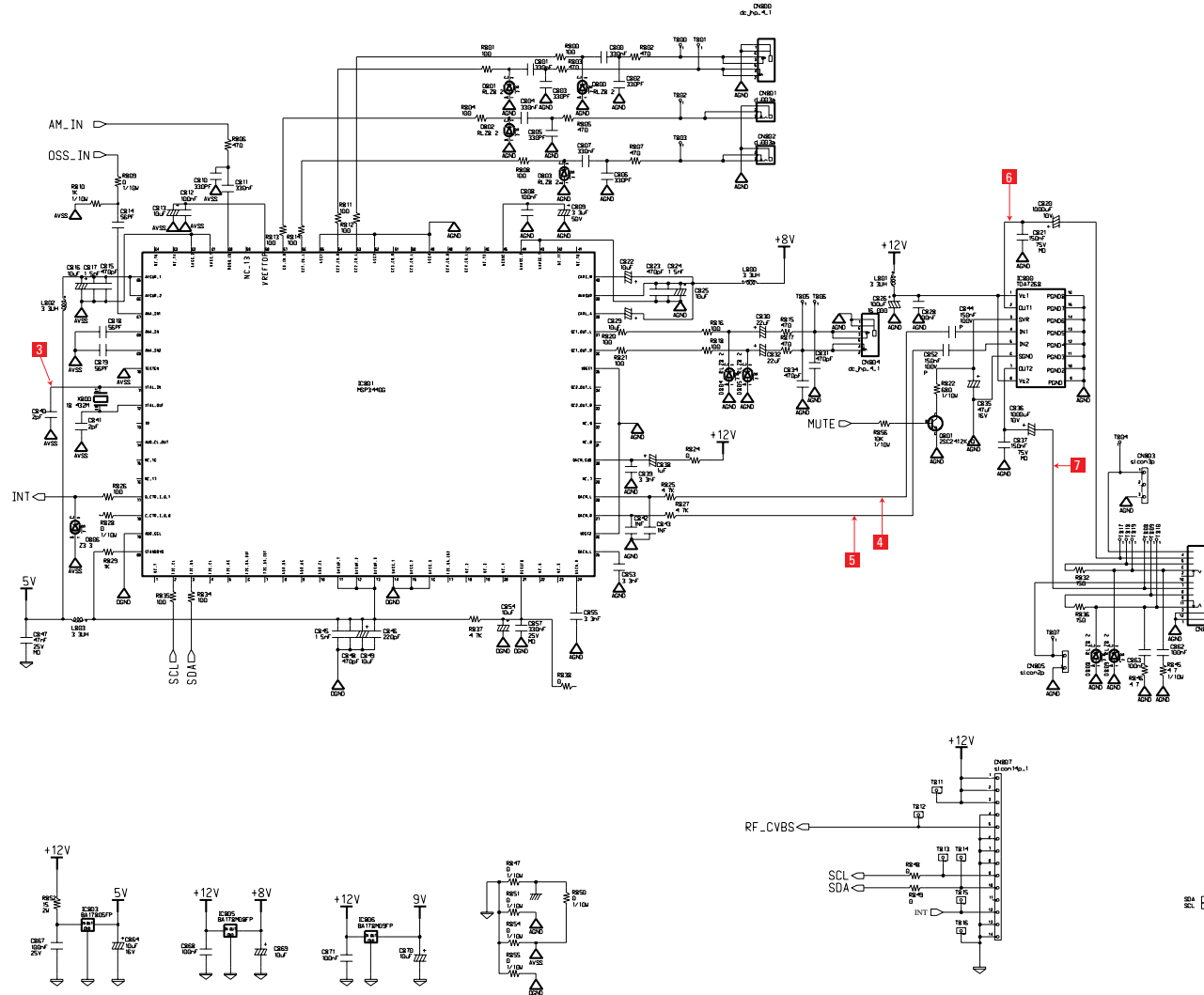

9-7 ADC / PLL Part Schematic Diagram (170MB)

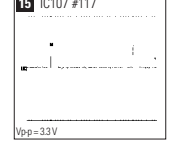
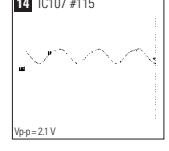
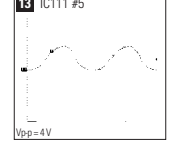
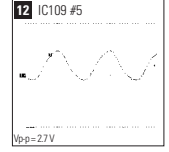
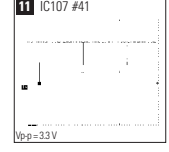
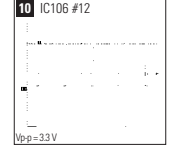
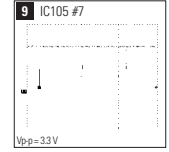
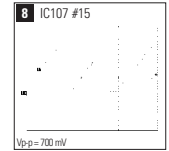
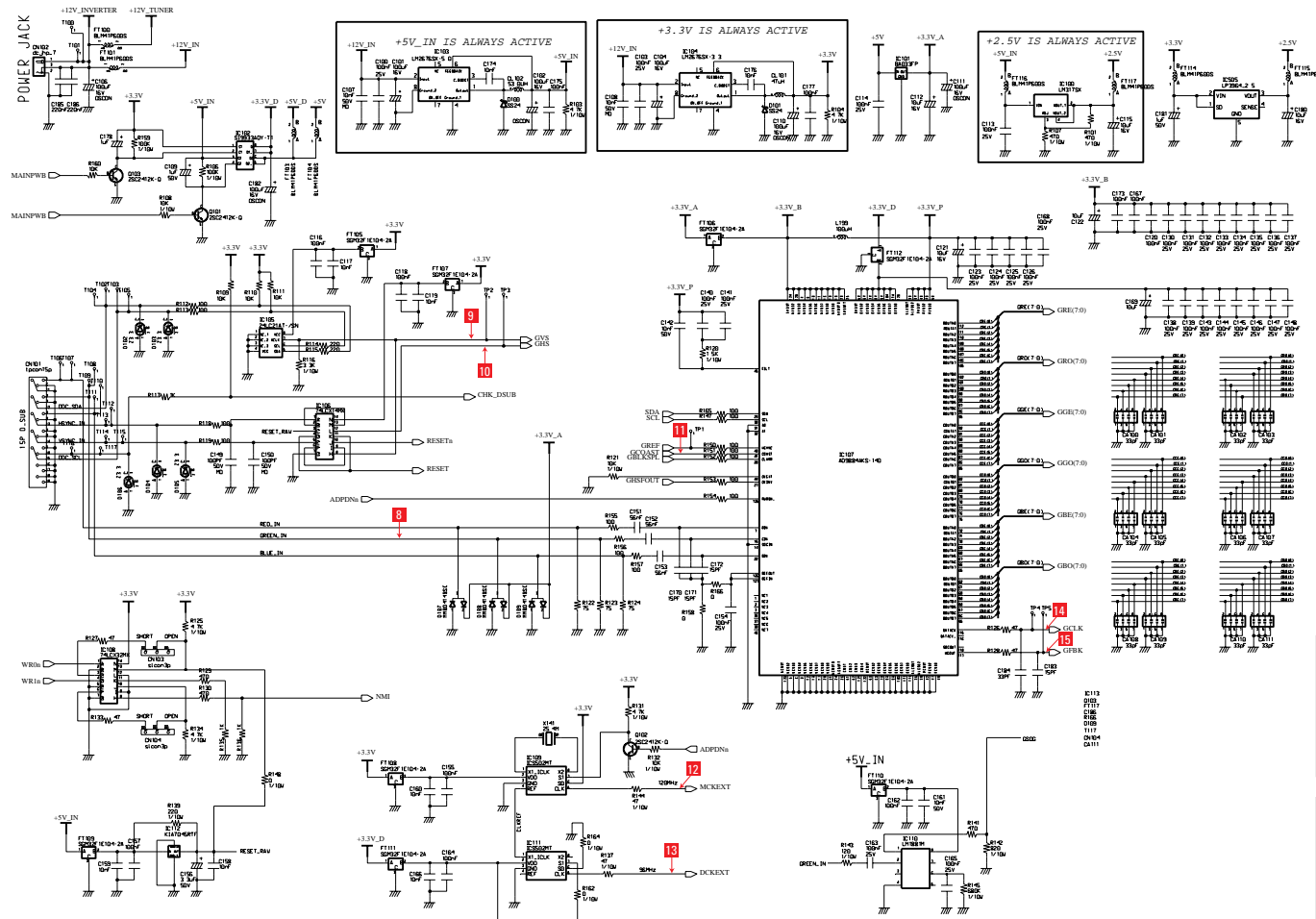

### 9-8 Video Decoder Part Schematic Diagram (170MB)

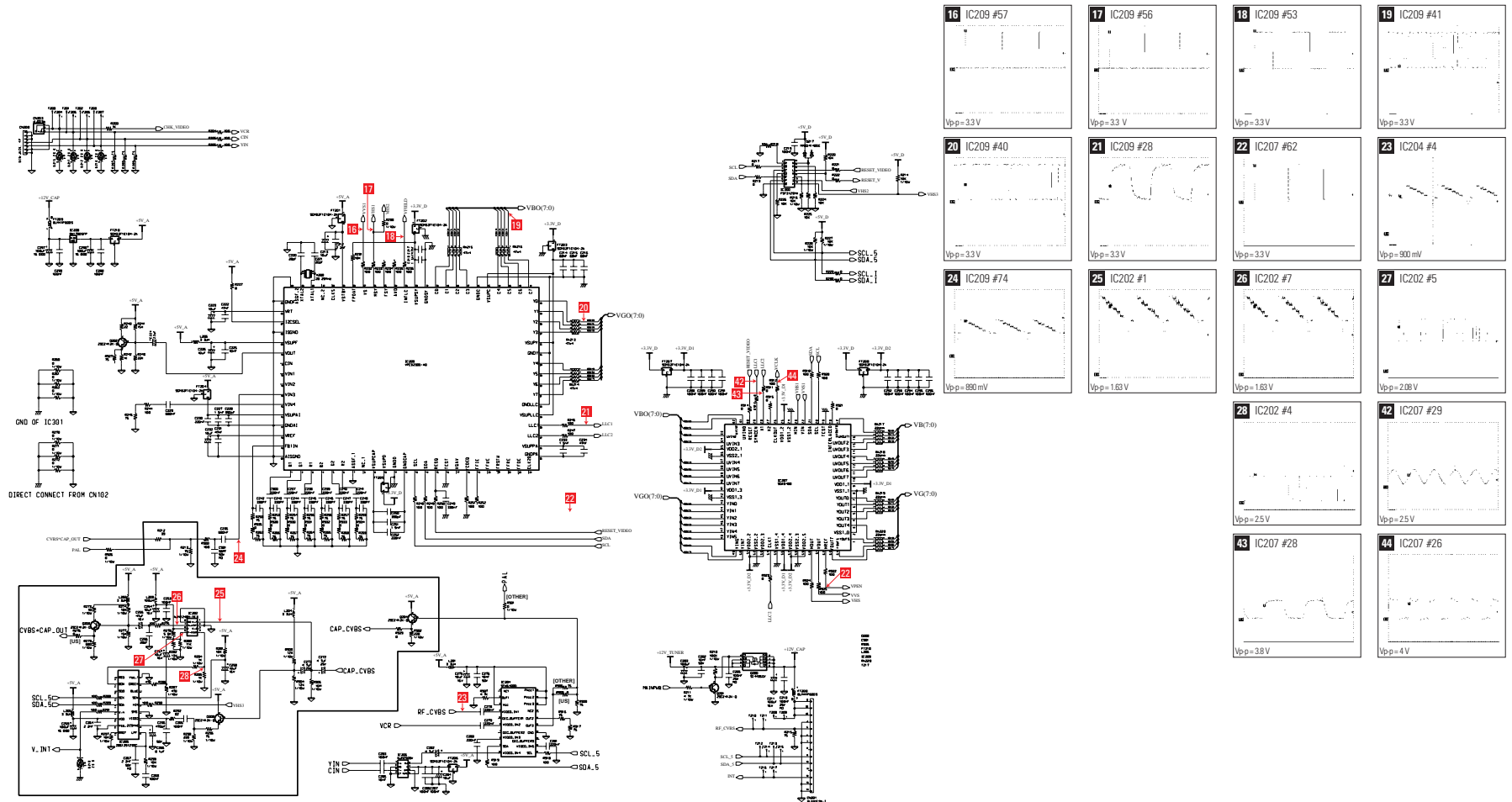

9-9 PW364 Part Schematic Diagram (170MB)

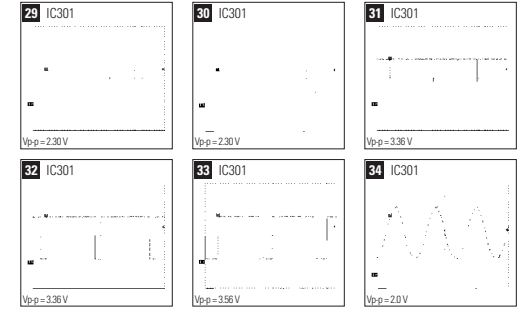
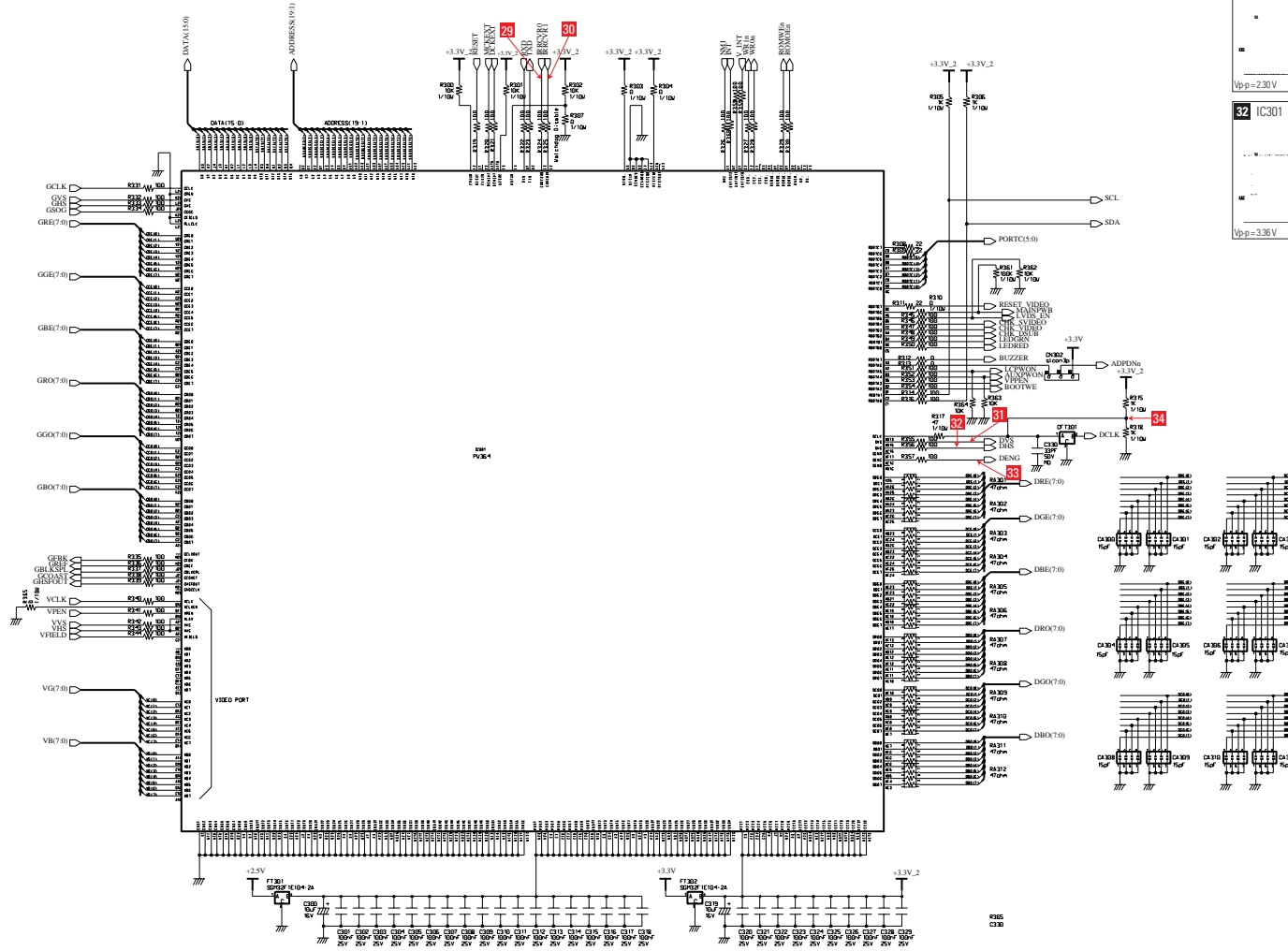

9-10 Memory Part Schematic Diagram (170MB)

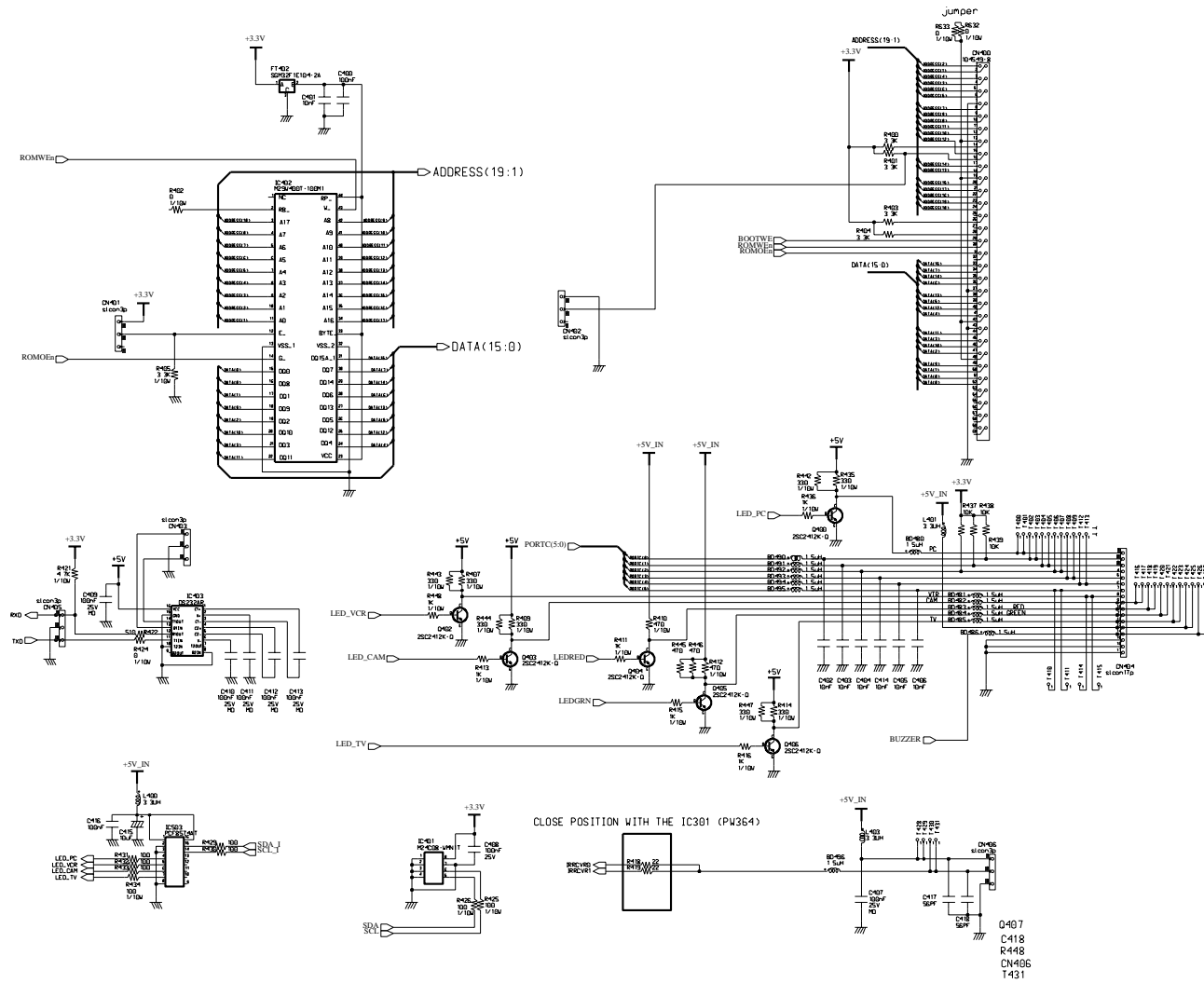



9-11 LVDS Part Schematic Diagram (170MB)

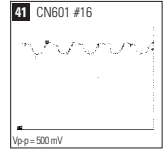
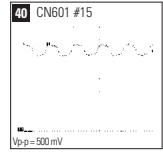
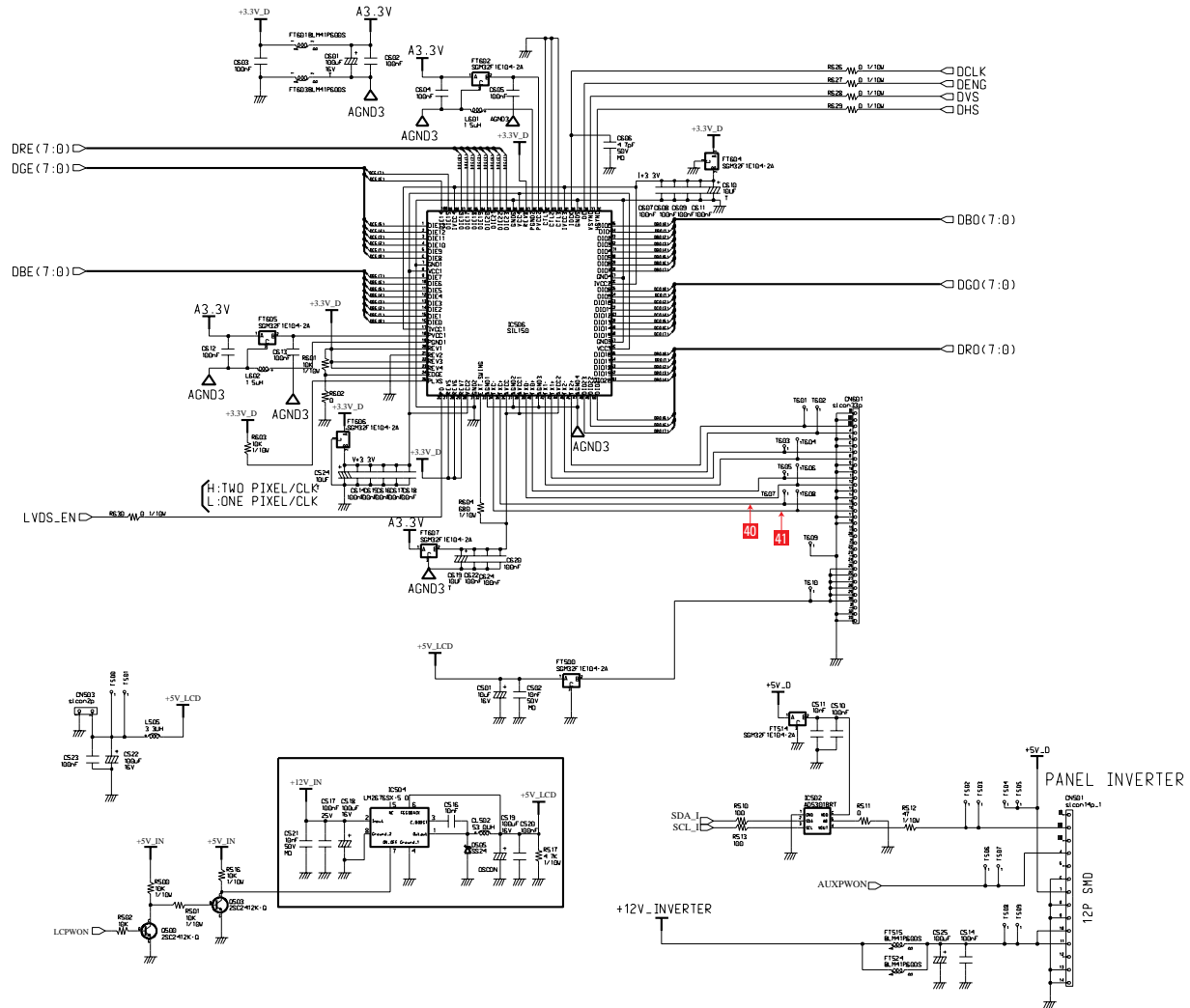

9-12 Audio Part Schematic Diagram (170MB)

